



# Kitchen & Servingtools

BANQUET.....	552
CLASSIC.....	554
DISPENSERS & EGG BOXES.....	581
DISPLAY TRAYS.....	582
EASYLIFT.....	558
MEASURING CUPS.....	584
PIZZA.....	588
PROFI.....	561
SPOONS.....	592
SQUEEZE BOTTLES.....	586
STRAINERS.....	578
STOP-TOOLS.....	556
TONGS.....	562
TOOLTIME.....	570
TWEEZERS.....	569
WHISKS.....	577

# BANQUET



Die Vorlegeserie BANQUET ist die passende Ergänzung zum Servieren am Buffet. Durch die mattierte Oberfläche und das gebogene Griffende wird BANQUET praktischen und optischen Ansprüchen gerecht.

The series BANQUET is the perfect addition for serving at the buffet. Due to the matt surface and the curved handle, BANQUET meets practical and optical requirements.

La serie BANQUET es la adición perfecta para servir en el buffet. Debido a la superficie mate y al mango curvado, BANQUET cumple con requisitos prácticos y ópticos.

La série BANQUET est l'ajout parfait pour servir au buffet. Grâce à la surface mate et la poignée incurvée, BANQUET répond aux exigences pratiques et optiques.



**Salat- / Servierlöffel „BANQUET“**  
salad spoon / serving spoon  
cuchara para ensalada / cuchara de servicio  
cuillère à salade / cuillère de service



	cm	Griff / handle cm	€
00588	6,0 x 5,0	17	5,60
00590	7,5 x 6,0	21	8,00



**Salatgabel „BANQUET“**  
salad fork  
tenedor de servicio para ensalada  
fourchette de service pour la salade



	cm	Griff / handle cm	€
00589	6,0 x 5,0	17	5,60
00591	7,5 x 6,0	21	8,00



00589      00591



**Schöpflöffel „BANQUET“**  
ladle  
cucharón  
louche



	cm	Griff / handle cm	€
00595	8,5 x 7,5	24	16,00



**Chafing Dish Löffel „BANQUET“**

serving spoon  
cuchara para servir  
cuillère de service



	cm	Griff / handle cm		€
00592	11 x 6,5	24		9,40
00593	11 x 6,5	24	geschlitzt / slotted	9,00



00593



**Dressinglöffel „BANQUET“**

dressing spoon  
cuchara de aliño  
cuillère à vinaigrette



	cm	Griff / handle cm		€
00594	6 x 4	30		11,50



**Pfannenwender „BANQUET“**

turner  
espátula  
spatule



	cm	Griff / handle cm		€
00587	10 x 7,5	21		9,00



**Fleischgabel „BANQUET“**

meat fork  
tenedor de carne  
fourchette à viande



	cm	Griff / handle cm		€
00596	8 x 2,5	13		4,90



**Serviergabel „BANQUET“**

fork  
tenedor de servicio  
fourchette de service



	cm	Griff / handle cm		€
00597	9 x 4	21		8,40



**Tortenheber „BANQUET“**

cake lifter  
pala de tartas  
pelle à gâteau  
**eine Kante gezahnt**  
one edge serrated  
un borde serrado  
denté sur un côté



	cm	Griff / handle cm		€
00598	14 x 6	13		7,00

## CLASSIC



### Servierlöffel „CLASSIC“

serving spoon  
cuchara de servicio  
cuillère de service



**Edelstahl Vintage-Look, ergonomisch profilierter Hohl-Griff**  
stainless steel vintage look, ergonomic designed handle  
acero inoxidable aspecto vintage, asa ergonómica  
acier inox look vintage, manche ergonomique

	cm	Griff / handle cm	Farbe / Colour		€
75920	8,0 x 6	21,5		vintage-look	9,30
75921	9,5 x 7	23,5		vintage-look	9,30



### Servierlöffel „CLASSIC“

serving spoon  
cuchara de servicio  
cuillère de service



**Edelstahl Vintage-Look, perforiert, Löcher Ø 4 mm, ergonomisch profilierter Hohl-Griff**  
stainless steel vintage look, perforated, holes Ø 4 mm, ergonomic designed handle  
acero inoxidable aspecto vintage, perforado, agujeros Ø 4 mm, asa ergonómica  
acier inox look vintage, perforé, trous Ø 4 mm, manche ergonomique

	cm	Griff / handle cm	Farbe / Colour		€
75922	9,5 x 7	23,5		vintage-look	9,30



### Suppenkelle „CLASSIC“

soup ladle  
cucharón de sopa  
louche de service



**Edelstahl Vintage-Look, ergonomisch profilierter Hohl-Griff**  
stainless steel vintage look, ergonomic designed handle  
acero inoxidable aspecto vintage, asa ergonómica  
acier inox look vintage, manche ergonomique

	Ø cm	Griff / handle cm	Farbe / Colour		€
75923	7	23		vintage-look	10,00
75924	9	24		vintage-look	11,00



### Saucengießlöffel „CLASSIC“

sauce / gravy ladle  
cucharón de salsa  
cuillère à sauce



**Edelstahl Vintage-Look, ergonomisch profilierter Hohl-Griff**  
stainless steel vintage look, ergonomic designed handle  
acero inoxidable aspecto vintage, asa ergonómica  
acier inox look vintage, manche ergonomique

	cm	Griff / handle cm	Farbe / Colour		€
75925	7 x 5,5	22		vintage-look	8,70



### Tortenneher / Tortenmesser „CLASSIC“

cake server / cake knife  
servidor de tartas / cuchillo para tartas  
pelle à tarte / couteau à tarte



**Edelstahl Vintage-Look, mit einer gezahnten Kante, ergonomisch profilierter Hohl-Griff**  
stainless steel vintage look, one edge serrated, ergonomic designed handle  
acero inoxidable aspecto vintage, canto dentado, asa ergonómica  
acier inox look vintage, bord microdenté, manche ergonomique

	cm	Griff / handle cm	Farbe / Colour		€
75926	8,0 x 5	10,5		vintage-look	8,60
75927	15,5 x 5	12,0		vintage-look	10,30





**Servierlöffel „CLASSIC“**

serving spoon  
cuchara de servicio  
cuillère de service



hochglanzpoliert, perforiert, Löcher Ø 4 mm, ergonomisch profilierter Hohl-Griff  
mirror polished, perforated, holes Ø 4 mm, ergonomic designed handle  
pulido brillante agujeros de Ø 4 mm, asa ergonómica  
brillant, trous Ø 4 mm, manche ergonomique

	cm	Griff / handle cm	€
75903	9,5 x 7	23,5	9,30



**Salatlöffel „CLASSIC“**

salad spoon  
cuchara para ensalada  
cuillère à salade



hochglanzpoliert, ergonomisch profilierter Hohl-Griff  
mirror polished, ergonomic designed handle  
pulido brillante, asa ergonómica  
poli brillant, manche ergonomique

	cm	Griff / handle cm	€
75902	8,0 x 6	21,5	9,30
75904	9,5 x 7	23,5	9,30



**Suppenkelle „CLASSIC“**

soup ladle  
cucharón de sopa  
louche de service



hochglanzpoliert, ergonomisch profilierter Hohl-Griff  
mirror polished, ergonomic designed handle  
pulido brillante, asa ergonómica  
poli brillant, manche ergonomique

	Ø cm	Griff / handle cm	ml.	€
75907	7	23	60	10,00
75908	9	24	100	11,00



**Saucengießlöffel „CLASSIC“**

sauce / gravy ladle  
cucharón de salsa  
cuillère à sauce



hochglanzpoliert, ergonomisch profilierter Hohl-Griff, fugenlos  
mirror polished, ergonomic designed handle, seamless  
pulido brillante, asa ergonómica, sin soldadura  
poli brillant, manche ergonomique, monobloc (sans soudure)

	cm	Griff / handle cm	ml.	€
75906	7 x 5,5	22	20	8,70

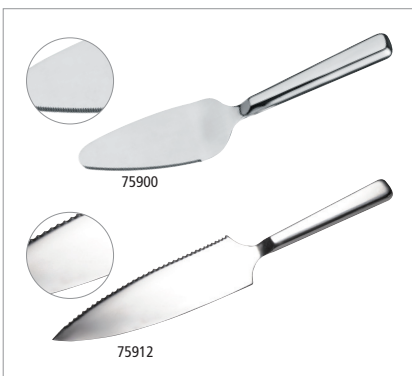

**Tortenheber „CLASSIC“**

cake lifter  
pala de tartas  
pelle à gâteau



hochglanzpoliert, mit einer gezahnten Kante, ergonomisch profilierter Hohl-Griff  
mirror polished, one edge serrated, ergonomic designed handle  
pulido brillante, canto dentado, mango ergonómico  
poli brillant, bord microdenté, manche ergonomique

	cm	Griff / handle cm	€
75900	8,0 x 5	10,5	8,60
75912	15,5 x 5	12,0	10,30

# STOP-TOOLS

Die STOP-Funktion verhindert, dass Gabel oder Löffel in das Gefäß rutschen.

The smart STOP-function prevent forks and spoon not to slip into the vessel.

La función STOP evita que los cubiertos se caigan dentro del recipiente.

La fonction STOP empêche les couverts de glisser dans le récipient.



**Servierlöffel**  
serving spoon  
cuchara para servir  
cuillère à servir

**Materialdicke 2,5 mm, ergonomischer, rutschfester Griff**  
material thickness: 2,5 mm, ergonomic antislip handle  
grosor: 2,5 mm, mango ergonómico antideslizante  
épaisseur : 2,5 mm, poignée ergonomique antidérapante



	cm	Griff / handle cm	€
00834	10 x 7,5	17	12,00



**Servierlöffel geschlitzt**  
slotted spoon  
cuchara para servir ranurada  
cuillère à servir rainurée

**Materialdicke 2,5 mm, ergonomischer, rutschfester Griff**  
material thickness: 2,5 mm, ergonomic antislip handle  
grosor: 2,5 mm, mango ergonómico antideslizante  
épaisseur : 2,5 mm, poignée ergonomique antidérapante



	cm	Griff / handle cm	€
00833	10 x 7,5	17	12,00



**Schöpflöffel**  
ladle  
cucharón  
louche

**Materialdicke 2,5 mm, ergonomischer, rutschfester Griff**  
material thickness: 2,5 mm, ergonomic antislip handle  
grosor: 2,5 mm, mango ergonómico antideslizante  
épaisseur : 2,5 mm, poignée ergonomique antidérapante



	Ø cm	Griff / handle cm	€
00832	9	17	13,00



**Fleischgabel**  
meat fork  
tenedor de carne  
fourchette à viande

**Materialdicke 2,5 mm, ergonomischer, rutschfester Griff**  
material thickness: 2,5 mm, ergonomic antislip handle  
grosor: 2,5 mm, mango ergonómico antideslizante  
épaisseur : 2,5 mm, poignée ergonomique antidérapante



	cm	Griff / handle cm	€
00831	10,5 x 4	17	12,00



**Servierlöffel geschlitzt**  
 slotted spoon  
 cuchara para servir ranurada  
 cuillère à servir rainurée  
**ergonomischer, rutschfester Griff**  
 ergonomic antislip handle  
 mango ergonómico antideslizante  
 poignée ergonomique antidérapante



	cm	Griff / handle cm	€
00664	11 x 7	25	6,80



**Servierlöffel**  
 serving spoon  
 cuchara para servir  
 cuillère à servir  
**ergonomischer, rutschfester Griff**  
 ergonomic antislip handle  
 mango ergonómico antideslizante  
 poignée ergonomique antidérapante



	cm	Griff / handle cm	€
00662	11 x 7	25	6,80



**Schöpföffel**  
 ladle  
 cucharón  
 louche  
**ergonomischer, rutschfester Griff**  
 ergonomic antislip handle  
 mango ergonómico antideslizante  
 poignée ergonomique antidérapante



	cm	Griff / handle cm	ml	€
00670	9 x 8	25	110	7,50



**Wender**  
 turner  
 espátula  
 spatule  
**ergonomischer, rutschfester Griff**  
 ergonomic antislip handle  
 mango ergonómico antideslizante  
 poignée ergonomique antidérapante



	cm	Griff / handle cm	€
00668	10 x 8	25	7,50



**Fleischgabel**  
 meat fork  
 tenedor de carne  
 fourchette à viande  
**ergonomischer, rutschfester Griff**  
 ergonomic antislip handle  
 mango ergonómico antideslizante  
 poignée ergonomique antidérapante



	cm	Griff / handle cm	€
00666	10 x 3,5	25	6,80



# EASYLIFT



Das Profimaterial Polyamid besteht aus Nylon und Fiberglas. Hitzebeständig bis 220°C, extra hochwertige Profi-Qualität, gut geeignet für antihafbeschichtete Pfannen, ergonomischer Griff.

Polyamide is made of nylon and fiberglass. Heat-resistant up to 220°C, extra high quality, perfect for non-stick-coated pots and pans, ergonomic handle.

Poliamide de nylon y fibra de vidrio. Brevemente al calor hasta 220°, alta calidad profesional, ideal para sartenes antiadherentes, mango ergonómico.

Polyamide de nylon et fibre de verre, haute résistance brièvement à la chaleur jusque 220°C, qualité professionnelle, idéal pour les poêles antiadhérentes, manche ergonomique.



## Bratenwender „EASYLIFT“

turner  
espátula  
spatule



	cm	Griff / handle cm	€
00603	11 x 9,5	23	6,70



## Pfannenwender „EASYLIFT“

turner  
espátula  
spatule



	cm	Griff / handle cm	€
00600	11,5 x 9,5	23	6,60





## Pfannenwender „EASYLIFT“

turner  
espátula  
spatule

	cm	Griff / handle cm	€
88642	13,5 x 9	18	4,80



## Pfannenwender „EASYLIFT“

turner  
espátula  
spatule

	cm	Griff / handle cm	€
88640	13 x 6,5	15	4,70



## Servierlöffel „EASYLIFT“

serving spoon  
cuchara de servicio  
cuillère de service

	cm	Griff / handle cm	€
88608	12 x 7	23	6,60
00607	12 x 7	23	perforiert / perforated 6,20



## Schaumlöffel „EASYLIFT“

skimmer  
espumadera  
écumoire

	Ø cm	Griff / handle cm	€
00602	11,5	23	6,70

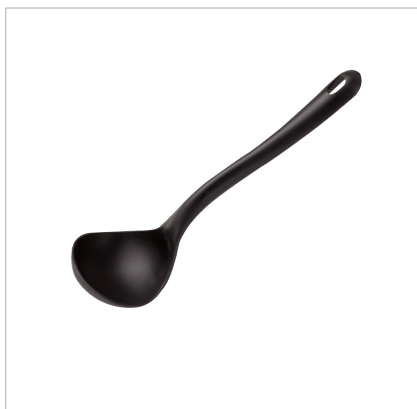

**Schöpflöffel „EASYLIFT“**

ladle  
cucharón  
louche



	Ø cm	Griff / handle cm	ml.	€
00606	9	23	100	6,90

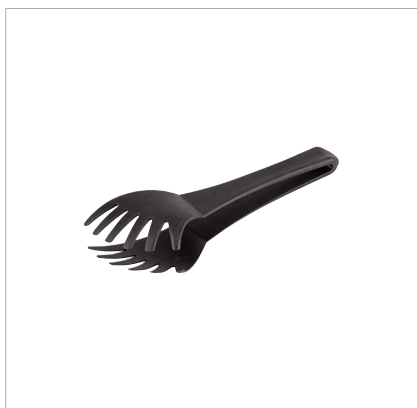

**Spaghettizange „EASYLIFT“**

spaghetti tongs  
pinzas para espaguetis  
pince à spaghettis



	cm	Griff / handle cm	€
88637	9 x 9	15	6,70

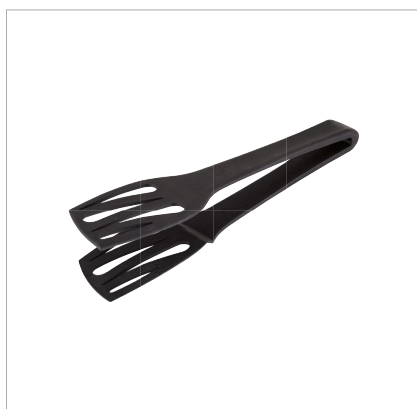

**Toastzange „EASYLIFT“**

sandwich tongs  
pinzas para sandwich  
pince à toasts



	cm	Griff / handle cm	€
00601	11 x 8	18	8,50



**Salatzange „EASYLIFT“**

salad tongs  
pinzas para ensalada  
pince à salade



	cm	Griff / handle cm	€
00629	8 x 5,5	17,5	6,50
00605	10 x 6,0	23,0	6,90

**Schöpflöffel „PROFI“**ladle  
cacillo  
louche

	Ø cm	Griff / handle cm	ml.	€
00711	6	28	50	12,20
00712	7	30	80	12,60
00713	8	32	125	13,60
00714	9	33	150	15,60
00715	10	35	250	16,30
00716	11	36	300	16,90

**Schaumlöffel „PROFI“**skimmer  
espumadera  
écumoire

	Ø cm	Griff / handle cm	€
00721	10	34	13,20
00722	12	37	14,10
00723	14	40	15,40

**Wender „PROFI“**turner  
espátula  
spatule

	cm	Griff / handle cm	€
00730	10 x 11,5	38	15,40

**Servierlöffel „PROFI“**serving spoon  
cuchara de servicio  
cuillère de service

	cm	Griff / handle cm	€
00672	11 x 7	29	9,20

**Spaghettilöffel „PROFI“**spaghetti spoon  
cuchara de espaguetis  
cuillère à spaghettis

	cm	Griff / handle cm	€
00673	10 x 7	29	9,90

## TONGS



### Universalzange all-purpose tongs pinza universal pince universelle



	cm	→ cm	Farbe / Colour	€
75825	7 x 5	22,5	vintage-look	10,90
75830	7 x 5	25,0	mirror polished	10,80
75831	7 x 5	25,0	gold-look	13,10
75832	7 x 5	25,0	copper-look	13,10



### Universalzange all-purpose tongs pinza universal pince universelle



hochglanzpoliert, mit Befestigungsclip  
mirror polished, with fastening clip  
pulido brillante, con clip de fijación  
poli brillant, avec clip de fixation

	→ cm	Farbe / Colour	€
75850	19,5	mirror polished	4,20
75851	19,5	copper-look	4,60
75852	19,5	gunmetal-look	4,60



Zange kann an einer Schale befestigt werden  
tongs can be attached to a bowl



### Eiszange ice tongs pinzas para hielo pince de la glace



hochglanzpoliert, mit Befestigungsclip  
mirror polished, with fastening clip  
pulido brillante, con clip de fijación  
poli brillant, avec clip de fixation

	→ cm	Farbe / Colour	€
75853	20	mirror polished	4,60
75854	20	copper-look	5,00
75855	20	gunmetal-look	5,00



Zange kann an einer Schale befestigt werden  
tongs can be attached to a bowl





**Universalzange**

all-purpose tongs  
pinza universal  
pinces universelle

Edelstahl, Vintage-Look

stainless steel  
acero inoxidable  
acier inox



	cm	→ cm	Farbe / Colour	€
75824	7 x 5	22,5	vintage-look	9,00



**Vorspeisenzange „BANQUET“**

appetizer tongs  
pinza para aperitivos  
pinces à apéritif

Vorderteil poliert, Stiel mattiert

front part: high-shiny, handle: matt-finish  
parte delantera pulida, asa mate  
partie avant polie, poignée matte



	cm	→ cm	€
75822	4,5 x 3,5	20	8,90



**Salatzange**

salad tongs  
pinza ensalada  
pinces à salade

hochglanzpoliert, beidseitig geschlitzt / mirror polished, slotted on both side  
pulido brillante, agujereada en 2 lados / poli brillant, perforéedes 2 côtés



	cm	→ cm	€
75801	5 x 2	24	6,30



**Spaghettizange**

spaghetti tongs  
pinza espaguetis  
pinces à spaghettis

hochglanzpoliert, fugenlos

mirror polished, seamless  
pulido brillante, sin soldaduras  
poli brillant, monobloc



	cm	→ cm	€
75810	6 x 3	19	4,80



**Gebäckzange**

pastry tongs  
pinza para pasteles  
pinces à gâteaux

hochglanzpoliert, fugenlos, extra schwere Qualität

mirror polished, seamless, extra heavy gauge  
pulido brillante, sin soldadura, alta calidad, resistente  
poli brillant, monobloc, qualité extra, robuste



	cm	→ cm	€
75807	8,5 x 4	27,5	9,70

## TONGS



### Salatzange „TIDLOS“

salad tongs  
pinza ensalada  
pince à salade

hochglanzpoliert, einseitig geschlitzt  
mirror polished, slotted on one side  
pulido brillante, agujereada en un lado  
poli brillant, perforée d'un seul côté



	cm	→ cm	€
75842	5 x 2	22	6,20



### Pastazange „TIDLOS“

pasta tongs  
pinza espaguetis  
pince à spaghettis

hochglanzpoliert, beidseitig geschlitzt  
mirror polished, slotted on both side  
pulido brillante, agujereada en 2 lados  
poli brillant, perforéedes 2 côtés



	cm	→ cm	€
75843	8 x 5,5	22,5	6,20



### Spargelzange „TIDLOS“

asparagus tongs  
pinzas para espárragos  
pince à asperges

hochglanzpoliert / mirror polished / pulido brillante / poli brillant



	cm	→ cm	€
75844	7 x 11	24,5	6,90



### Gebäckzange „TIDLOS“

pastry tongs  
pinza para pasteles  
pince à gâteaux

hochglanzpoliert / mirror polished / pulido brillante / poli brillant



	cm	→ cm	€
75840	6,5 x 4,5	21	4,40



### Servierzange „TIDLOS“

serving tongs  
pinza universal  
pince universelle

hochglanzpoliert / mirror polished / pulido brillante / poli brillant



	cm	→ cm	€
75841	7 x 4,5	21	5,20



**Salatzange**

salad serving tongs  
pinza de ensalada  
pince à servir la salade

**hochglanzpoliert, einfache Handhabung**

mirror polished, convenient handling  
pulido brillante, manejo cómodo  
poli brillant, manipulation aisée



	cm	→ cm	€
00685	7 x 4,5	25	16,40



**Universalzange**

all - purpose tongs  
pinzas multiusos  
pince multi-usages

**hochglanzpoliert, einfache Handhabung**

mirror polished, convenient handling  
pulido brillante, manejo cómodo  
poli brillant, manipulation aisée



	cm	→ cm	€
00688	7 x 4,5	25	16,40



**Brot- und Gebäckzange**

bread and pastry tongs  
pinza para pan y bollería  
pince à pain ou viennoiseries

**hochglanzpoliert, einfache Handhabung**

mirror polished, convenient handling  
pulido brillante, manejo cómodo  
poli brillant, manipulation aisée



	cm	→ cm	€
00686	7 x 4,5	25	16,40



**Brot- und Gebäckzange**

bread and pastry tongs  
pinza para pan y bollería  
pince à pain ou viennoiseries

**hochglanzpoliert, einfache Handhabung**

mirror polished, convenient handling  
pulido brillante, manejo cómodo  
poli brillant, manipulation aisée



	cm	→ cm	€
00687	7 x 4,5	25	16,40

## TONGS

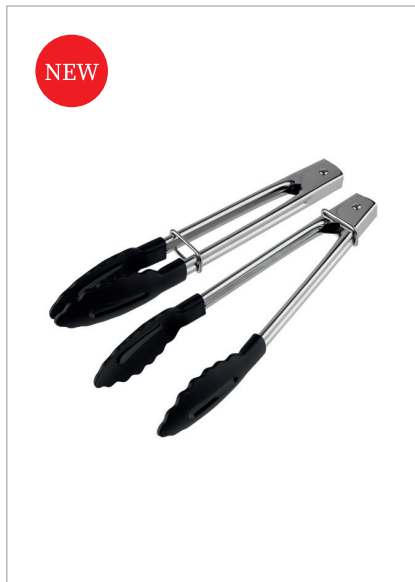

### Mini-Universalzange, 2er Set

mini all-purpose tongs, 2 pcs.  
mini pinzas multusos, set de 2  
mini pince multi-usages, set de 2



**Edelstahl poliert, Greifer aus Polyamid, inklusive Haltering**

polished stainless steel, polyamide gripper, including retaining ring  
acero inoxidable pulido, pinzas de poliamida, anillo de retención incluido  
acier inox poli, pincas en polyamide, anneau de retenue inclus

	→ cm	pcs.	€/ set
75870	18	2	9,00



### Universalzange

all - purpose tongs  
pinza universal  
pince universelle



**hochglanzpoliert, einseitig geschlitzt**

mirror polished, slotted on one side  
pulido brillante, agujereada en un lado  
poli brillant, perforée d'un seul côté

	cm	→ cm	€
75800	5 x 2	24	5,00

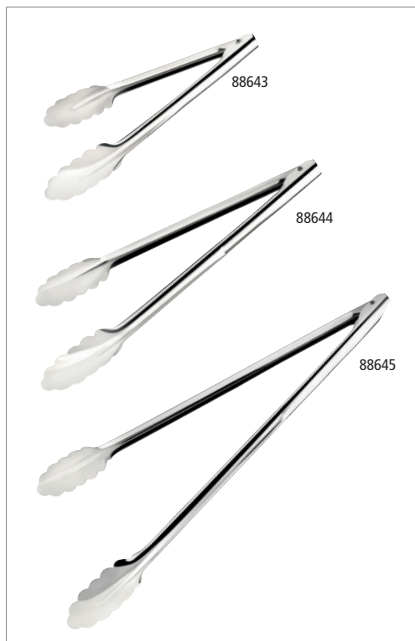

### Allzweckzange

multipurpose tongs  
pinza multi-usos  
pince universelle multi-usages



**hochglänzend, mit Feder und Verschlusschieber, dekorative Greiferform**

mirror polished, with spring and retaining clip, decorative gripper form  
pulido brillante, con muelle y cierre deslizante, gancho con forma decorativa  
poli brillant, avec mécanisme de verrouillage, forme de pince décorative

	cm	→ cm	€
88643	4 x 3	24	3,70
88644	4 x 3	30	4,50
88645	4 x 3	40	4,90



### Aufschnitt- / Allzweckzange

sausage tongs  
pinza salchichas  
pince à saucisses



**hochglanzpoliert, fugenlos / mirror polished, seamless / pulido brillante, sin soldadura / poli brillant, monobloc**

	cm	→ cm	€
75806	3 x 2,5	16	4,00





**Gebäckzange**

pastry tong  
pinza para pasteles  
pince à gâteaux  
hochglanzpoliert, perforiert  
mirror polished, perforated  
pulido brillante, perforado  
poli brillant, perforée



	cm	→ cm	€
75804	6,5 x 3	19,5	8,40



**Gebäck- / Tortenzange**

pastry tong  
pinza para pasteles  
pince à gâteaux  
hochglanzpoliert, fugenlos  
mirror polished, seamless  
pulido brillante, sin soldadura  
poli brillant, monobloc



	cm	→ cm	€
75803	7 x 3,5	17,5	5,40



**Eisportionierer**

ice cream scoop  
cuchara para helado  
cuillère à glace



hochglanzpoliert, mit Edelstahlfeder (physikalisch bedingt nicht korrosionsbeständig)  
mirror polished, spring steel, spring is not stainless  
pulido brillante, muelle de acero especial, no resistente al óxido  
poli brillant, ressort acier spécial, non résistant à l'oxydation

	Ø cm	→ cm	litr.	€
71006	6,5	23,5	1/12	11,60
71005	6,0	22,5	1/16	11,60
71004	5,5	22,0	1/20	11,60
71003	5,0	22,0	1/24	11,60
71002	5,0	21,5	1/30	11,60
71001	4,5	21,0	1/36	11,60



**Messlöffelsatz**

set measuring spoon  
juego de cucharas medidoras  
jeu de cuillère à mesure



Löffel hochglanzpoliert, Stiele matt poliert, Skalierung:

1 Esslöffel, 1 Teelöffel, 1/2 Teelöffel, 1/4 Teelöffel

bowl mirror polished, handles matt polished, measures:

table spoon, tea spoon, 1/2 tea spoon, 1/4 tea spoon

bol medidor brillante, mango mate medidas:

1 cuchara de sopa, 1 cuchara de té, 1/2 cuchara de té, 1/4 cuchara de té

corps brillant, manche mat, mesures:

1 cuillerée à soupe, 1 cuillerée à thé, 1/2 cuillère à thé, 1/4 de cuillère à thé

	cm	€
75600	14 x 4,5	6,70

## TONGS



### Universalzange „SPECTRA“

all-purpose tongs  
pinzas multiusos  
pince multi-usages



Griff matt beschichtet / matt coated handle / mango recubierto de mate / poignée revêtue de mat

	→ cm	Farbe / Colour	€
75860	24	gelb	4,60
75861	24	rot	4,60
75862	24	grün	4,60
75863	24	blau	4,60
75864	24	schwarz	4,60

HACCP Farbkennzeichnung Konzept  
HACCP color coding concept



matte Antirutschummatellung  
matt anti-slip coating



### Universalzange „SPECTRA“

all-purpose tongs  
pinzas multiusos  
pince multi-usages



Griff matt beschichtet / matt coated handle / mango recubierto de mate / poignée revêtue de mat

	→ cm	Farbe / Colour	€
75865	30	gelb	5,40
75866	30	rot	5,40
75867	30	grün	5,40
75868	30	blau	5,40
75869	30	schwarz	5,40

HACCP Farbkennzeichnung Konzept  
HACCP color coding concept



matte Antirutschummatellung  
matt anti-slip coating

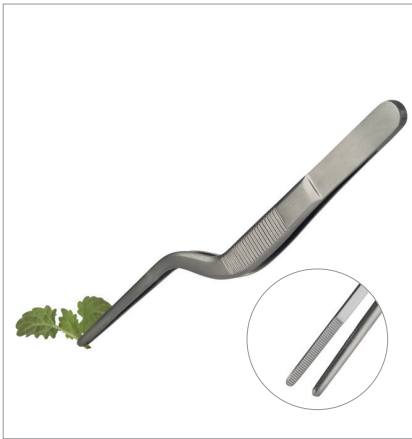

**Pinzettenzange**

fine tongs / tweezer  
pinza de emplatar  
pince à dresser



hochglanzpoliert, geriffelte Grifffläche, schwere Qualität  
mirror polished, ribbed handle, heavy gauge  
pulido brillante, mango cómodo ranurado, alta calidad  
poli brillant, manche rainuré antiglisse, qualité extra

	→ cm	€
75820	16	6,60



**Pinzettenzange**

fine tongs / tweezer  
pinza de emplatar  
pince à dresser



hochglanzpoliert, geriffelte Grifffläche, schwere Qualität  
mirror polished, ribbed handle, heavy gauge  
pulido brillante, mango cómodo ranurado, alta calidad  
poli brillant, manche rainuré antiglisse, qualité extra

	→ cm	€
75821	30	9,90



**Pinzettenzange**

fine tongs / tweezer  
pinza de emplatar  
pince à dresser



hochglanzpoliert, geriffelte Grifffläche, schwere Qualität  
mirror polished, ribbed handle, heavy gauge  
pulido brillante, mango cómodo ranurado, alta calidad  
poli brillant, manche rainuré antiglisse, qualité extra

	→ cm	€
75809	30	8,40



**Pinzettenzange**

fine tongs / tweezer  
pinza de emplatar  
pince à dresser



hochglanzpoliert, geriffelte Grifffläche, abgerundete Spitzen vorne, schwere Qualität  
mirror polished, ribbed handle, rounded on the tops, heavy gauge  
pulido brillante, mango cómodo ranurado, alta calidad, puntas redondeadas  
poli brillant, manche rainuré antiglisse, qualité extra, pointes arrondies

	→ cm	€
75808	14,5	5,50

# TOOLTIME



## Kugelausstecher - doppelt „TOOLTIME“

melon baller - double  
vaciador doble de bola  
moule à boule double



zum Formen von Kugeln aus Obst, Gemüse oder Butter, Edelstahl mit geschärften Rändern  
to form balls out of fruits, vegetables, butter, etc., stainless steel with sharpened edge  
para hacer bolas con frutas, verduras, mantequilla, etc. acero inoxidable con borde afilado  
pour faire des boules de fruits, légumes, beurre, etc. inox, bord affûté

	Ø cm	→ cm	€
88810	2,2 + 2,5	16,5	7,50
88811	2,2 + 3,0	17,0	7,60

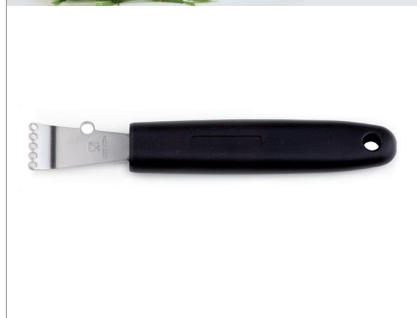

## Fadenschneider / Zester „TOOLTIME“

decorator / zester  
cuchillo de decoración cincelador  
couteau zesteur



zum Abziehen von feinsten Schalenstreifen, ideal zum Dekorieren von Torten und Desserts  
to peel off very fine stripes of paring, these stripes are ideal to decorate desserts, cakes, etc.  
para pelar tiras muy finas, ideal para decorar postres, tartas, etc.  
pour couper en lanières fines, idéal pour la décoration de gâteaux et desserts, etc.

	Ø cm	→ cm	€
88823	0,2 + 0,5	14,5	4,20





**Ziseliermesser „TOOLTIME“**  
 canele / decorating knife  
 cuchillo de decoración cincelador acanalado  
 couteau zesteur cannelé



zum Einritzen von Linien und Mustern in hartschaliges Obst und Gemüse, Edelstahl mit geschärften Rändern

to score lines or design in hard fruits and vegetables, stainless steel with sharpened edge  
 para dibujar líneas en frutas o verduras de piel dura, acero inoxidable con borde afilado  
 pour découper des lignes et motifs sur fruits et légumes à peau dure ou pour peler les zestes des citrons ou oranges, inox, bord affûté

	→ cm	€
88826	15	4,20



**Sparschäler „TOOLTIME“**  
 peeler  
 pelador  
 peleur



für Links- und Rechtshänder geeignet, mit zwei starren Klingen aus extra geschärftem + gehärtetem Edelstahl

useable left- and right handed, with 2 inflexible blades made out off sharpened, extra hardened stainless steel

para diestros y zurdos, con 2 cuchillas rígidas inox afiladas y muy resistentes  
 pour gauchers ou droitiers, 2 lames rigides affûtés en inox extra-résistant

	→ cm	€
88827	17	2,80



**Pendelschäler „TOOLTIME“**  
 swivel peeler  
 pelador reversible  
 éplucheur droitier/gaucher



für Links- und Rechtshänder, ideal für das Schälen von Tomaten, mit 2 beweglichen Klingen

suitable for right and left handed, ideal to peel tomatoes, with 2 flexibles blades

apto para diestros y zurdos, ideal para pelar tomates, con 2 hojas flexibles  
 pour gauchers ou droitiers, idéal pour peler les tomates, 2 lames flexibles

	→ cm	€
88850	16,5	4,60



**Apfelnuker „TOOLTIME“**  
 apple corer  
 descorazonador de manzana  
 vide-pomme



durch leichtes Drehen kann das Kerngehäuse von Äpfeln, Birnen und anderen Früchten sorgsam herausgeholt werden, Edelstahl mit geschärften Rändern

with a light turn cores of apples, pears and other fruits can be cut off easily, stainless steel with sharpened edge

para descorazonar muy fácilmente manzanas, peras y otras frutas  
 pour évider facilement les pommes, poires ou autres fruits

	∅ cm	→ cm	€
88836	2,2	21	3,30



**Cocktailmesser „TOOLTIME“**

bar knife  
cuchillo para cóctel  
couteau cocktail

mit 2 Zinken zum Aufspießen von Zitrusseiben  
with 2 prongs to pick up slices of lemon  
con 2 dientes para pinchar las rodajas de limón, etc.  
avec 2 dents pour les rondelles de citron et autres décorations



	→ cm	€
88846	21	4,80

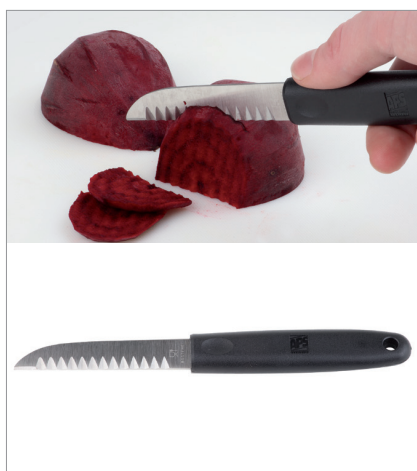

**Dekoriermesser „TOOLTIME“**

decorating knife „cannelé“  
cuchillo acanalador  
couteau cannelé

gezahnte Klinge aus geschärftem Edelstahl  
serrated sharpened blade, stainless steel  
hoja de sierra afilada, acero inoxidable  
lame inox microdentée



	→ cm	€
88843	19	5,90



**Pendelschäler „TOOLTIME“**

swivel peeler  
pelador lama pivotante  
peleur lame pivotante

zum schnellen und sparsamen Schälen von Obst und Gemüse, mit beweglicher Klinge  
to peel fruits and vegetables with flexible blade  
para pelar frutas y verduras con hoja flexible  
pour couper des fruits et légumes avec lame flexible



	→ cm	€
88834	17	5,20



**Käsehobel „TOOLTIME“**

cheese slicer  
rebanador de queso  
couteau tranche-fromage

zum Schneiden von dünnen Käsescheiben  
to cut thin slices of cheese  
para cortar lonchas finas de queso  
pour couper de fines tranches de fromage



	→ cm	€
88853	21,5	5,90



**Austernöffner „TOOLTIME“**

oyster knife  
 abre ostras  
 couteau à huîtres



zum einfachen Aufbrechen von Austern, mit Fingerschutz, Edelstahl mit geschärften Rändern  
 to open oysters easily, with guard, stainless steel with sharpened edge  
 para abrir ostras fácilmente con protección para los dedos, acero inoxidable con punta afilada  
 pour ouvrir facilement les huîtres avec protection pour les doigts, inox, pointe affûtée

	→ cm	€
88839	14,5	7,10



**Austernmesser „TOOLTIME“**

oyster knife  
 abre ostras  
 couteau à huîtres



Edelstahlklinge zum Einstecken in die Schale, mit Fingerschutz  
 stainless steel blade for prick the shell, with finger guard  
 para abrir ostras fácilmente con protección para los dedos  
 pour ouvrir facilement les huîtres avec protection pour les doigts

	→ cm	€
88840	15	4,10



**Pizzaschneider „TOOLTIME“**

pizza cutter  
 cortador de pizza  
 coupe-pizza



ergonomischer Griff  
 ergonomic handle  
 mango ergonómico  
 manche ergonomique

	∅ cm	→ cm	€
88949	10	20	6,70



**Pizzaroller „TOOLTIME“**

pizza cutter  
 cortador de pizza  
 roulette à pizza



	∅ cm	→ cm	€
88829	6	18,5	4,80



**Winkelpalette „TOOLTIME“**

turner  
espátula  
spatule

flexible Edelstahlklinge  
flexible blade stainless steel  
hoja flexible acero inoxidable  
lame inox flexible



	cm	→ cm	€
88935	34,0 x 5	47,5	9,90
88937	24,0 x 4	36,0	7,10
88938	18,5 x 3	32,0	6,40



**Winkelpalette „TOOLTIME“**

spatula  
espátula  
spatule

flexible Edelstahlklinge  
flexible blade stainless steel  
hoja flexible acero inoxidable  
lame inox flexible



	cm	→ cm	€
88928	17 x 5	30	6,80



**Gebäckpalette „TOOLTIME“**

pastry spatuala  
paleta pastelera  
spatule pâtissière

flexible Edelstahlklinge  
flexible blade stainless steel  
hoja flexible acero inoxidable  
lame inox flexible



	cm	→ cm	€
88932	17 x 7,5	29,5	7,60



**Wender „TOOLTIME“**

turner  
espátula  
spatule

flexible Edelstahlklinge  
flexible blade stainless steel  
hoja flexible acero inoxidable  
lame inox flexible



	cm	→ cm	€
88933	15 x 6	27,5	6,10





Wender „TOOLTIME“

turner  
espátula  
spatule

perforiert, flexible Edelstahlklinge  
perforated, flexible blade stainless steel  
hoja flexible inox agujereada  
lame ajourée inox flexible



	cm	→ cm	€
88940	24,5 x 7,5	37,5	9,40



Wender „TOOLTIME“

turner  
espátula  
spatule

flexible Edelstahlklinge  
flexible blade stainless steel  
hoja flexible acero inoxidable  
lame inox flexible



	cm	→ cm	€
88939	24 x 7,5	37,5	9,10



Wender „TOOLTIME“

turner  
espátula para plancha  
spatule

flexible Edelstahlklinge  
flexible blade stainless steel  
hoja flexible acero inoxidable  
lame inox flexible



	cm	→ cm	€
88941	20 x 7,5	33	8,00
88942	15 x 9,0	28	7,90



Spachtel / Fettabstecher „TOOLTIME“

scraper  
espátula plancha  
spatule coudée spéciale grill

starre Edelstahlklinge  
rigid blade stainless steel  
hoja rígida de acero inoxidable  
lame rigide inox



	cm	→ cm	€
88946	17 x 10,0	30	9,10
88947	15 x 7,5	28	7,60





**Spachtel / Schaber „TOOLTIME“**

scraper  
 espátula plancha  
 spatule coudée spéciale grill  
**starre Edelstahlklinge**  
 rigid blade stainless steel  
 hoja rígida acero inoxidable  
 lame inox rigide



	cm	→ cm	€
88929	11 x 10	25	7,60

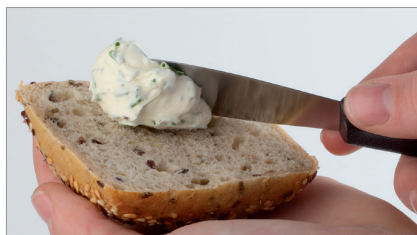

**Aufstrichmesser „TOOLTIME“**

sandwich knife  
 cuchillo para untar  
 couteau à tartiner  
**flexible Edelstahlklinge**  
 flexible blade stainless steel  
 hoja flexible acero inoxidable  
 lame inox flexible



	cm	→ cm	€
88948	8,5 x 3	18,5	2,80



**Teigschaber / Abstecher „TOOLTIME“**

dough scraper  
 corta pasta  
 coupe-pâte  
**starre Edelstahlklinge**  
 rigid blade stainless steel  
 hoja rígida de acero inoxidable  
 lame rigide inox



	cm	€
88930	15,5 x 8	5,20

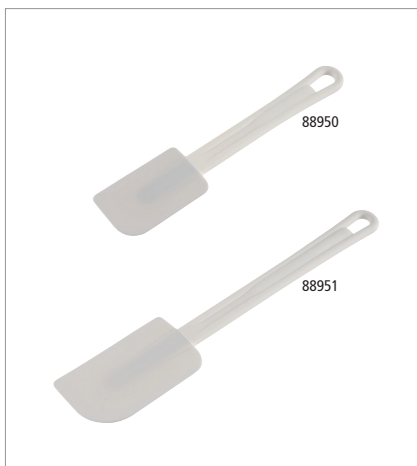

**Teigspatel / Stielschaber**

dough spatula / handle scraper  
 espátula masa / rascador  
 spatule à pâte / raclette  
**Aufhängeloch**  
 with hanging hole  
 con agujero para colgar  
 avec trou de suspension



	→ cm	€
88950	25,5	10,00
88951	35,5	12,00

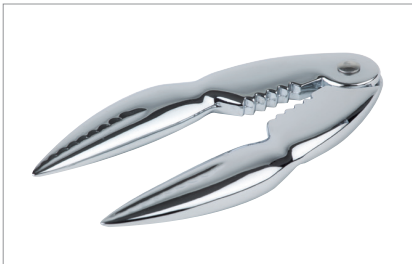

**Hummerbrecher**

lobster cracker  
pinza bogavante  
pince à homard



	cm	€
74201	14 x 5,5	8,80

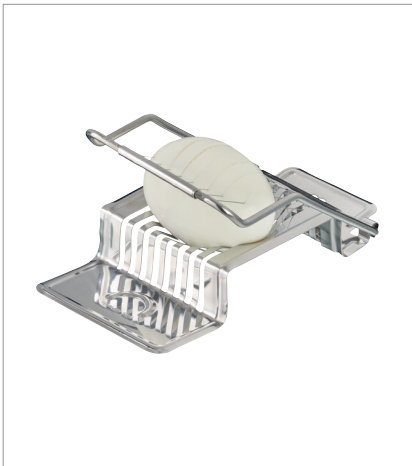

**Eierschneider**

egg cutter  
corta huevos  
coupe-oeufs



zum Längs- und Querteilen von hart gekochten Eiern

to cut hard-boiled eggs  
corta a rodajas un huevo duro  
en rondelles

	cm	↑ cm	€
88099	14,5 x 8	2,5	2,50

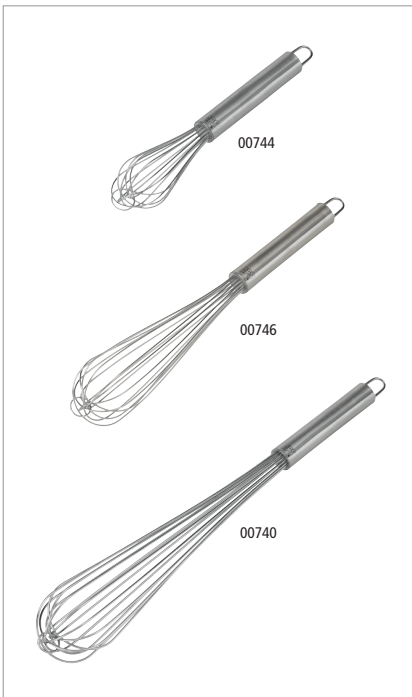

**Schneebeesen**

whisk  
batidor  
fouet



	Drähte / wires	→ cm	€
00744	8	28	6,60
00745	8	33	6,80
00746	8	38	8,40
00747	8	43	9,50
00740	8	48	10,00

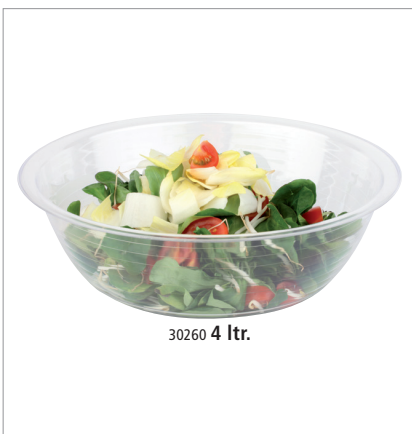

**Schüssel**

bowl  
ensaladera  
saladier  
glasklar  
crystal clear  
cristalina  
transparent



	Ø cm	↑ cm	ltr.	€
30260	32,5	10	4	5,10
30263	40,0	12	8	10,40

## STRAINERS



### Saucen- und Fondantrichter

sauce and confectionary funnel  
embudo para salsa y confitería  
entonnoir à sauce et confiserie



**ergonomischer Griff, Maßskalierung innen, mit 3 Düsen Ø 4, 5, 6 mm, inklusive Ständer und Auffangschale**

ergonomic handle, scaling inside, with 3 different nozzles Ø 4, 5, 6 mm, including wire rack and dripping dash

mango ergonómico, escalado interior, con 3 boquillas, Ø 4, 5, 6 mm, incl. pie de alambre y bandeja recoge gotas

manche ergonomique, mise à l'échelle à l'intérieur, 3 douilles de Ø 4, 5 et 6 mm, inclut pied avec ramasse-gouttes

	Ø cm	↑ cm	ltr.	€
77338	21	31,5	1,5	98,00



Anwendungsbeispiel  
application example



Maßskalierung innen  
scaling inside



### Gazespitzsieb

conical strainer with wire gauze  
colador chino de malla  
chinois renforcé avec maille fine



**hochglanzpoliert, mit rundem Hohlgriff, ca. 9 Löcher pro 1 cm<sup>2</sup>**

mirror polished, 9 holes per 1 cm<sup>2</sup>

pulido brillante, mango hueco, 9 agujeros por 1 cm<sup>2</sup>

poli brillant, manche creux, 9 trous pour 1 cm<sup>2</sup>

	Ø cm	↑ cm	Griff / handle cm	€
88717	25	19	24	44,00



### Spitzsieb

conical strainer  
colador cónico  
chinois



**mit Lochung Ø 1,5 mm, auch in der Kegelspitze, mit Flachstiel, mit Stützstiel zum Einhaken in den Topfrand**

with Ø 1,5 mm holes (including the tip), with flat handle, with supporting hook

con agujeros finos de Ø 1,5 mm (incluida la punta), con mango plano y gancho

perforations fines 1,5 y compris à la pointe, manche plat et crochet

	Ø cm	↑ cm	Griff / handle cm	€
00771	23	18	16,5	26,00



### Barsieb

bar strainer  
colador de cóctel  
tamis cocktail



	Ø cm	↑ cm	Griff / handle cm	€
93318	8,5	5	11,5	4,50





**Wasserbadschüssel**  
 bain marie boiling bowl  
 cazo para baño maría  
 récipient bain-marie



hochglanzpoliert, mit Drahtgriff Ø 5 mm  
 mirror polished, with wire handle Ø 5 mm  
 pulido brillante, mango varilla Ø 5 mm  
 poli brillant, manche fil épaisseur Ø 5 mm

	Ø cm	↑ cm	Griff / handle cm	ltr.	€
74731	18	9	15	1,5	14,70



Anwendungsbeispiel  
 Application Example



**Trichter „PROFI“**

funnel  
 embudo  
 entonnoir  
 mit Öse  
 with eyelet  
 con ojal  
 avec œillet



	Ø cm	Ø mm Durchlass		€
30066	8	11		1,30
30068	12	12		2,20
30071	21	20	mit Sieb / incl. strainer	7,60



erleichtert das Einfüllen  
 facilitates filling



mit einsetzbarem Sieb  
 incl. insertable strainer



## STRAINERS

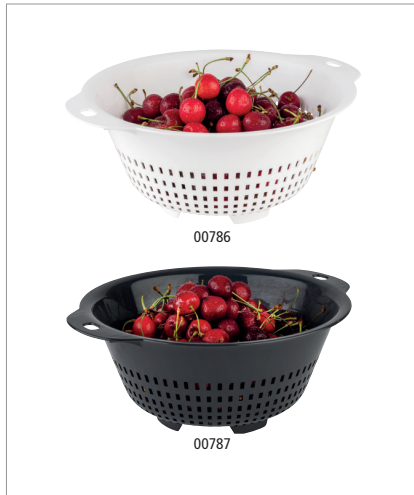

### Seiheer strainer colador passoire



2 Griffe: je 2 cm / 2 handles: each 2 cm / 2 asa: 2 cm cada una / 2 poignées: 2 cm chacune

	Ø cm	↑ cm	Farbe / Colour	€
00786	27,5	12		8,00
00787	27,5	12		8,00



### Seiheer strainer colador passoire



mit 2 Muschelgriffen / with 2 shell shaped grips / con dos asas / à 2 anses moulées

	Ø cm	↑ cm	€
00780	36	19	12,50



### Pommes-Frites-Seiheer chip colander escurridor de fritos égouttoir à friture



herausnehmbarer Locheinsatz, mit Handgriff  
removable drainer, with handle  
fondo de colador desmontable, con asa  
fond démontable, avec poignée

	Ø cm	↑ cm	€
00785	39	19	34,00



### Salzstreuer salt shaker salero salière



Pommes-Frites Streuer mit Schraubkappe  
for french fries, cover to screw  
para patatas fritas, tapa de rosca  
pour les frites, couvercle à visser

	Ø cm	↑ cm	€
00772	8	17	15,00



### Salzstreuer salt shaker salero salière



Pommes-Frites Streuer mit Schraubkappe  
for french fries, cover to screw  
para patatas fritas, tapa de rosca  
pour les frites, couvercle à visser

	Ø cm	↑ cm	€
00779	8	17	9,90





**Dosierspender**  
dosing dispenser  
dosificador  
distributeur de dosage



Behälter aus Glas, ideal zum Dosieren von Marmelade, Joghurt und Saucen (ohne Stücke /Fruchtfleisch)  
glass container, ideal for dosing jam, yoghurt and sauces (without pieces /pulp)  
recipiente de cristal, ideal para dosificar mermelada, yogur y salsas (sin trozos/pulpa)  
récipient en verre, idéal pour doser la confiture, le yaourt et sauces (sans morceaux /pulpe)

	∅ cm	↑ cm	ltr.	€
93290	13	31	1,7	24,00



Hubvolumen 15 ml  
stroke volume 15 ml



**Dosierspender**  
dispenser  
dispensador de salsa  
doseur à sauce



	cm	↑ cm	ltr.	GN	€
93280	17,6 x 16,2	27	2,6	1/6	26,00

Dosierpumpe, Hubvolumen 30 ml  
dosing pump / riser tube, swept volume 30 ml  
bomba de salsa, sola, cada dosis 30 ml  
pompe à sauce, 30 ml par dose



	cm	↑ cm	ltr.		€
93281	12,5 x 4,5	26	0,30	fits to 93280	18,00



**Dosierpumpe**  
dosing pump / riser tube  
bomba de salsa, sola  
pompe à sauce



Hubvolumen 30 ml / swept volume 30 ml / cada dosis 30 ml / 30 ml par dose

	∅ cm	↑ cm		€
88271	4,5	40		11,10



**Eier-Box**  
eggs box  
caja para huevos  
boîte à oeufs



mit luftdichtem Deckel, für 4 Lagen à 30 Eier, Lieferung inkl. 4 Lagen, Größe Lage: 28 x 28 cm  
with airtight cover, capacity: 4 trays of 30 eggs, delivery with 4 trays, size of tray: 28 x 28 cm  
capacidad para 4 bandejas de 30 huevos, tapa hermética, se entrega con 4 bandejas, formato bandejas 28 x 28 cm, apto para lavavajillas  
pour 4 plateaux de 30 oeufs chacun, apte pour 4 plateaux plats, couvercle hermétique, livré avec 4 plateaux, dimension plateau 28x28 cm, lavable en lave-vaisselle

	cm	↑ cm	GN	€
82419	35,4 x 32,5	20	2/3	39,90

4 Lagen / 4 trays / 4 bandejas / 4 plateaux

82420				12,50
-------	--	--	--	-------

## DISPLAY TRAYS



### Ausstellblech / Thekenblech

display tray  
bandeja pastelera  
plaque pâtissière

hitzebeständig bis 230°C

heat-resistant up to 230°C

resistente al calor hasta 230 °C

résistant à la chaleur jusqu'à 230°C



	cm	↑ cm	€
13377	40 x 25	2	13,00
13378	48 x 32	2	15,20
13379	60 x 40	2	20,00



### Mehlschaufel „PRO“

scoop

pala

pelle à farine

stehende Schaufel, auch für Flüssigkeiten geeignet

standing scoop, also applicable for liquids

pala, ápto también para líquidos

adaptée pour poudres et liquides



	cm	↑ cm	ltr.	€
00610	25 x 9	4,5	0,25	2,90
00611	31 x 12	5,5	0,5	3,50
00612	35 x 13	6,0	0,7	5,10

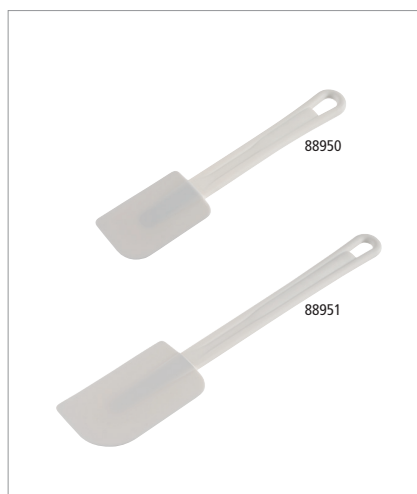

### Teigspatel / Stielschaber

dough spatula / handle scraper

espátula masa / rascador

spatule à pâte / raclette

Aufhängeloch

with hanging hole

con agujero para colgar

avec trou de suspension



	→ cm	€
88950	25,5	10,00
88951	35,5	12,00



**Backform**

baking pan  
marco pastelero  
forme à gateaux

stufenlos verstellbar, aus flexiblem Edelstahl

adjustable, made of flexible stainless steel

ajustable, de acero inoxidable flexible

ajustable, en acier inox flexible



	cm	↑ cm	€
00042	19 x 28 - 34 x 54	5	17,90



Anwendungsbeispiel  
application example



**Tortenring**

cake setting ring  
aro de tarta  
cercle à gateaux

stufenlos verstellbar

adjustable

ajustables

ajustables



	Ø cm	↑ cm	€
00040	16,5 - 32	7	8,40



Anwendungsbeispiel  
application example



**Schaumpeisering**

mousse ring  
aro redondo para semifríos  
cercle à mousse rond

matt poliert, fugenlos

matt polished, seamless

pulido mate, sin soldadura

poli mat, sans soudure



	Ø cm	↑ cm	€
00098	6	4,5	3,20
00099	7	4,5	3,70
00092	8	4,5	3,80
00093	10	4,5	5,30
00094	12	4,5	7,00



**Schaumpeiseringe, 5er Set**

mousse ring, 5 pcs.  
juego aros para emplatar o para semifríos  
jeu de cercles à mousse inox, ronds

5-teilig: 4 Formen + 1 Verdichter, matt poliert, fugenlos

5 pcs. set: 4 shapes and 1 pusher, matt polished, seamless

juego de 5 piezas: 4 aros redondos y 1 pulsador, para dar forma, satinado sin soldadura

jeu de 5 pièces: 4 cercles et 1 poussoir. Idéal pour dressage sur assiette ou mousse, poli mat, sans soudure



	Ø cm	↑ cm	pcs.	€/ set
00110	6	4,5	5	17,60
00113	8	4,5	5	19,00

# MEASURING CUPS

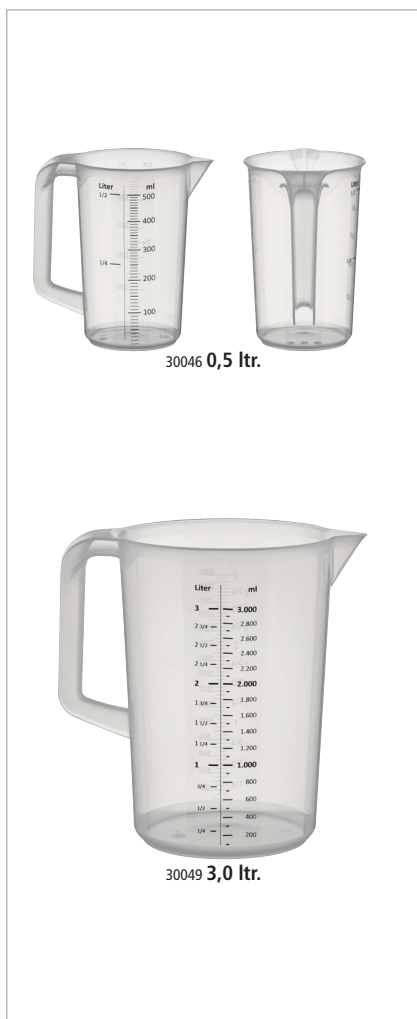

30046 0,5 ltr.

30049 3,0 ltr.

## Messbecher „PRO“ measuring cup jarra graduada pichet gradué



mit geschlossenem Griff, mit geprägter Maßskalierung außen, l- und ml-Liter-Einteilung  
with closed handle, with stamped printed liter and ml scale  
con asa cerrada, con escala estampada de litros y ml  
avec poignée fermée, avec échelle en litres et ml imprimée et tamponnée

	Ø cm	↑ cm	ltr.	€
30046	9	14,0	0,5	3,40
30047	12	16,5	1,0	4,50
30048	15	20,5	2,0	7,80
30049	17	23,5	3,0	10,00
30057	20	25,5	5,0	12,60



einfaches Eingießen  
easy pouring



30059 0,25 ltr.



30063 2 ltr.

Messbecher „STACKABLE“

measuring cup  
jarra graduada  
pichet gradué



mit offenem Griff und geprägter Maßskalierung außen, platzsparend stapelbar

with open handle and embossed dimension scaling on the outside, space-saving stackable

con asa abierta y escala de dimensiones en relieve en el exterior, apilable para ahorrar espacio

avec une poignée ouverte et une échelle de dimensions en relief à l'extérieur, empilable et peu encombrante

	Ø cm	↑ cm	ltr.	€
30059	7	12,0	0,25	2,50
30061	9	14,0	0,5	3,10
30062	12	16,5	1,0	4,10
30063	15	20,5	2,0	7,20



offener Griff  
open handle



einfaches Eingießen  
easy pouring



stapelbar  
stackable



30072 1 ltr.



30058 1 ltr.

inkl. Spritzschutz / incl. splash guard

Rührbecher mit Deckel „MIXUP“

stirring cup with lid  
vaso agitador con tapa  
tasse à remuer avec couvercle



inklusive Spritzschutz und geprägter Maßskalierung außen, platzsparend stapelbar

included splash guard with open handle and embossed dimension scaling on the outside, space-saving stackable

protección contra salpicaduras incluida con asa abierta y escala de dimensiones en relieve en el exterior, apilable para ahorrar espacio

protection contre les éclaboussures incluse avec une poignée ouverte et une échelle de dimensions en relief à l'extérieur, empilable et peu encombrante

	Ø cm	↑ cm	ltr.	Farbe / Colour	€
30072	12,5	16	1	■ french grey	7,90
30058	12,5	16	1	□ transparent	7,90



Griff mit Daumenmulde  
handle with thumb recess



mit Silikonring  
with silicone ring



inklusive Spritzschutz  
inclusive splash guard



1 ltr.

Messbecher  
graduated jug  
jarra graduada  
pichet gradué



außen hochglanzpoliert, innen matt poliert, mit Maßskalierung außen

outside mirror polished, inside matt polished, with stamped liter scale

exterior pulido brillante, interior pulido mate con escalado en litros

extérieur poli brillant, intérieur poli mat, graduation en litres

	Ø cm	↑ cm	ltr.	€
30045	10	14	1	13,40



## SQUEEZE BOTTLES



### Quetschflasche squeeze bottle bote dosificador flexible bouteille verseuse souple



mit Schraubdeckel und Verschlusskappe, ideal für Dressing und Saucen  
with tight-screw and cap, ideal for dressing and sauce  
con tapa de rosca y tapón, ideal para aliño y salsas  
avec couvercle à visser et bouchon de fermeture, idéal pour vinaigrette et sauces

	Ø cm	↑ cm	ltr.	Farbe / Colour	€
93259	8	26,5	1,025	White	2,30
93260	8	26,5	1,025	Yellow	2,30
93261	8	26,5	1,025	Red	2,30



große Öffnung  
big mouth opening



### Quetschflasche squeeze bottle bote dosificador flexible bouteille verseuse souple



mit Schraubdeckel und Verschlusskappe, ideal für Dressing und Saucen  
with tight-screw and cap, ideal for dressing and sauce  
con tapa de rosca y tapón, ideal para aliño y salsas  
avec couvercle à visser et bouchon de fermeture, idéal pour vinaigrette et sauces

	Ø cm	↑ cm	ltr.	Farbe / Colour	€
93155	6,5	24	0,65	Yellow	1,90
93156	6,5	24	0,65	Red	1,90
93157	6,5	24	0,65	White	1,90



**Quetschflasche, 6er Set**

squeeze bottle, 6 pcs.  
bote dosificador flexible, set de 6  
bouteille verseuse souple, set de 6



**mit Schraubdeckel und Verschlusskappe, ideal für Dressing und Saucen**

with tight-screw and cap, ideal for dressing and sauce

con tapa de rosca y tapón , ideal para aliño y salsas

avec couvercle à visser et bouchon de fermeture, idéal pour vinaigrette et sauces

	Ø cm	↑ cm	ltr.	Farbe / Colour	pcs.	€/ set
93250	5	18,0	0,26	White	6	7,40
93251	5	18,0	0,26	Yellow	6	7,40
93252	5	18,0	0,26	Red	6	7,40
93253	7	20,0	0,49	White	6	10,20
93254	7	20,0	0,49	Yellow	6	10,20
93255	7	20,0	0,49	Red	6	10,20
93256	7	26,5	0,76	White	6	11,60
93257	7	26,5	0,76	Yellow	6	11,60
93258	7	26,5	0,76	Red	6	11,60



mit Verschlusskappe  
with cap



große „Öffnung“  
big „mouth opening“



**Quetschflasche**

squeeze bottle  
bote dosificador flexible  
bouteille verseuse souple



**ideale Größe, um Speiseteller mit Saucen zu verzieren, mit Verschlusskappe**

ideal size to garnish plates with sauces, with cap

tamaño ideal para decorar platos con salsas, con tapón

taille idéale pour décorer assiettes avec des sauces, avec bouchon

	Ø cm	↑ cm	ltr.	€
93154	5	16	0,2	1,50
93163	6	21	0,35	2,40



**Quetschflasche „MINI“, 4er Set**

squeeze bottle, 4 pcs.  
bote dosificador flexible, 4 pz.  
bouteille verseuse souple, 4 pc.



**mit Schraubdeckel und Verschlusskappe, ideal für Dressing und Saucen**

with tight-screw and cap, ideal for dressing and sauce

con tapa de rosca y tapón , ideal para aliño y salsas

avec couvercle à visser et bouchon de fermeture, idéal pour vinaigrette et sauces

	Ø cm	↑ cm	ltr.	pcs.	€/ set
93225	3,0	8,5	0,03	4	5,50
93226	3,5	9,5	0,05	4	5,90



# PIZZA PANS



9 sizes



## Pizzaform

pizza pan  
molde de pizza  
moule à pizza



**Blaublech, nicht beschichtet, lange Lebensdauer, hitzebeständig bis 360 °C**  
blue steel, without coating, long endurance, heat resistant up to 360 °C  
chapa azul, sin revestimiento, larga vida útil, resistente al calor hasta 360 °C  
métal, sans revêtement, longue durée de vie, à la chaleur jusqu'à 360 °C

	Ø cm	↑ cm	€
73502	16 - 18	2,5	4,00
73505	22 - 24	2,5	6,70
73506	24 - 26	2,5	7,20
73507	26 - 28	2,5	7,50
73508	28 - 30	2,5	7,90
73509	30 - 32	2,5	8,40
73510	34 - 36	2,5	8,60
73511	38 - 40	2,5	10,40
73513	48 - 50	3,0	15,50



stapelbar  
stackable



## Pizzaform

pizza pan  
molde de pizza  
moule à pizza



**Blaublech, rechteckig, Rand umgelegt, hitzebeständig bis 360 °C**  
blue steel baking sheet, rectangular, heat resistant up to 360 °C  
chapa azul rectangular, borde plgado, resistente al calor hasta 360 °C  
métal, rectangulaire, bord plié, à la chaleur jusqu'à 360 °C

	cm	↑ cm	€
88256	60 x 40	2,5	26,00

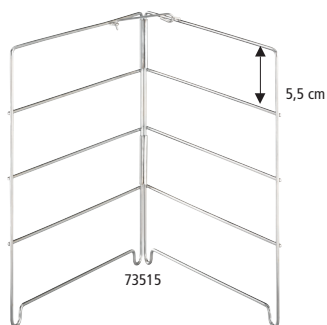

### Gestell für Pizzaformen

rack for pizza pans  
rejilla para pizzas  
support pour moules à pizza  
zusammenklappbar für Pizzaformen Ø 28 cm,  
Abstand zwischen den Ebenen 5,5 cm  
foldable rack for pizza dishes ø 28 cm,  
distance between the levels 5.5 cm  
rejilla plegable de para moldes de pizza de Ø 28 cm,  
distancia entre los niveles 5,5 cm  
support en pliable pour les moules à pizza de Ø 28 cm,  
distante entre les niveaux 5,5 cm



	cm	↑ cm	€
73515	26 x 25	26	7,60



backofengeeignet  
suitable for oven

Pizzaform für Ø 28 cm  
pizza dish for Ø 28 cm

### Pizzaform

pizza pan  
molde de pizza  
moule à pizza



	Ø cm	↑ cm	mm	€
73507	26 / 28	2,5	1	7,50

### Pizzaschaufel

pizza peel  
pala de pizza  
pelle à pizza



	cm	→ cm	€
88080	35 x 30,5	90	39,20
88081	35 x 30,5	130	47,30

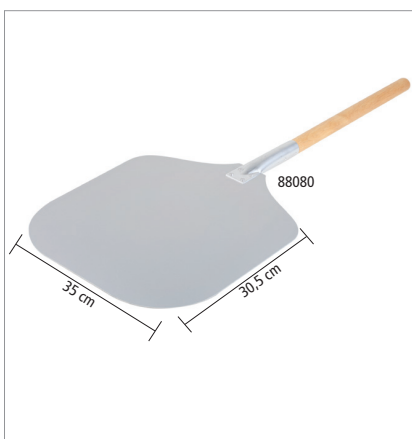

## PIZZA



### Teig- und Pizzaballenbehälter dough and pizza ball container recipiente para masa y bolas de pizza récipient à pâte et boules à pizza



**Innenmaß 56,5 x 36,5 cm, H: 8,5 cm**  
inner dimension 56,5 x 36,5 cm, H: 8,5 cm  
medida interior 56,5 x 36,5 cm, H: 8,5 cm  
dimension intérieure 56,5 x 36,5 cm, H: 8,5 cm

	cm	↑ cm	ltr.	€
82442 <small>NEW</small>	60 x 40	9	17	14,00
82440	60 x 40	7	13	12,00



stapelbar  
stackable

passender Deckel  
fitting lid  
tapa adecuada  
couvercle approprié



	cm	↑ cm	ltr.	€
82441	60 x 40	1		10,00



### Mehlschaufel „PRO“

scoop  
pala  
pelle à farine  
**stehende Schaufel, auch für Flüssigkeiten geeignet**  
standing scoop, also applicable for liquids  
pala, ápto también para líquidos  
adaptée pour poudres et liquides



	cm	↑ cm	ltr.	€
00610	25 x 9	4,5	0,25	2,90
00611	31 x 12	5,5	0,5	3,50
00612	35 x 13	6	0,7	5,10



### Teigschaber / Abstecher „TOOLTIME“

dough scraper  
corta pasta  
coupe-pâte  
**starre Edelstahlklinge**  
rigid blade stainless steel  
hoja rígida de acero inoxidable  
lame rigide inox



	cm	ltr.	€
88930	15,5 x 8		5,20



**Backhandschuhe**

baking mittens  
manoplas de panadero  
gants de boulanger

**Leder, gefüttert, Einheitsgröße, mit Stulpen, extrem hitzebeständig bis 250°C**  
leather, inner lining, one size, with cuffs, extremely heat resistant up to 250°C  
cuero interior forrado, talla única, resiste a temperaturas hasta 250°C  
cuir intérieur doublé, taille unique, résiste à maxi 250°C

	→ cm	€
88090	45	28,00

**Korkuntersetzer**

cork mat  
salvamanteles  
dessous-de-plat liège

**ideal für Servier- und Eisenpfannen**

ideal for iron pan  
ideal para servir en sartenes de chapa  
idéal pour présenter les poêles forgées sur table



	∅ cm	↑ cm	€
73750	24	2	15,40

**Pizzaschneider „TOOLTIME“**

pizza cutter  
cortador de pizza  
coupe-pizza

**ergonomischer Griff**  
ergonomic handle  
mango ergonómico  
manche ergonomique



	∅ cm	→ cm	€
88949	10	20	6,70

**Pizzaroller „TOOLTIME“**

pizza cutter  
cortador de pizza  
roulette à pizza



	∅ cm	→ cm	€
88829	6	18,5	4,80

## SPOONS | WOOD



### Salatbesteck „OLIVE“, 2er Set

spoon, 2 pcs.  
cuchara, set de 2  
cuillère, set de 2

aus Olivenholz  
olive wood  
madera de olivo  
en bois d'olivier



	cm	→ cm	€/ set
00841	9,5 x 8,5	17,0	17,30
00842	7,5 x 6,0	22,5	11,00



Anwendungsbeispiel  
application example



Anwendungsbeispiel  
application example



### Löffel „OLIVE“

spoon  
cuchara  
cuillère

aus Olivenholz, ideal für Reis, Gemüse...  
olive wood, ideal for rice, vegetables...  
madera de olivo, ideal para arroz, verduras...  
en bois d'olivier, idéal pour le riz, les legumes...



	cm	→ cm	€
00840	9,5 x 8,5	17	16,00



### Schaufel „OLIVE“

scoop  
pala  
pelle

aus Olivenholz, ideal für Gewürze, Körner etc.  
olive wood, ideal for spices, grains etc.  
madera de olivo, ideal para especias, granos etc.  
en bois d'olivier, idéal pour les épices, céréales, etc.



	→ cm	€
01020	13,5	7,40





**Löffel „OLIVE“, 2er Set**

spoon, 2 pcs.  
cuchara, set de 2  
cuillère, set de 2

aus Olivenholz, ideal für Gewürze  
olive wood, ideal for spices  
madera de olivo, ideal para especias  
en bois d'olivier, idéal pour les épices



	→ cm	pcs.	€ / set
01018	14	2	6,60



**Honiglöffel „OLIVE“**

honey spoon  
cuchara de miel  
cuillère à miel

aus Olivenholz  
olive wood  
madera de olivo  
en bois d'olivier



	→ cm	€
01019	15	4,90



**Löffel „ACACIA“**

spoon  
cuchara  
cuillère

aus Akazienholz, ideal für Reis, Gemüse...  
acacia wood, ideal for rice, vegetables...  
madera de acacia, ideal para arroz, verduras...  
bois d'acacia, idéal pour le riz, les légumes...



	cm	→ cm	€
00599	9 x 6,5	23,5	5,50

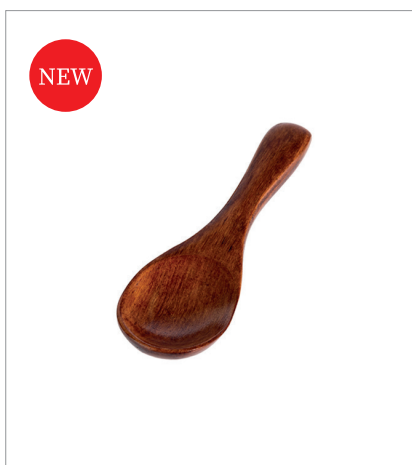

**Löffel**

spoon  
cuchara  
cuillère

Nanmu Holz / nanmu wood / madera de nanmu / bois de nanmu



	cm	→ cm	€
87027	3,5 x 3	10	3,00



## DELICATESSEN SPOONS



**Feinkost- / Olivenlöffel, 6er Set**  
 delicatessen / olives spoon, 6 pcs.  
 cuchara gourmet / para aceitunas, set de 6  
 cuillère gourmet / à olives, set de 6

SAN  
KUNSTSTOFF



geloht  
 perforated  
 perforadas  
 perforées

	cm	→ cm	pcs.	Farbe / Colour	€/ set
88598	6 x 9	27	6	■	12,00



**Feinkostlöffel, 6er Set**  
 delicatessen spoon, 6 pcs.  
 cuchara gourmet, set de 6  
 cuillère gourmet, set de 6

SAN  
KUNSTSTOFF



aus Kunststoff  
 plastic  
 plástico  
 plastique

	Ø cm	→ cm	pcs.	Farbe / Colour	€/ set
88627	6	23	6	■	10,00
88628	6	23	6	■	10,00



**Dressinglöffel**  
 dressing spoon  
 cuchara de aliño  
 cuillère à sauce

SAN  
KUNSTSTOFF



aus Kunststoff  
 plastic  
 plástico  
 plastique

	Ø cm	→ cm	ml.	Farbe / Colour	€
88636	6	34	50	■	3,90
88609	6	34	50	■	3,90



**Schneidbrettständer**  
cutting board rack  
soporte para tablas  
rack pour planches à découper

für 6 Schneidbretter bis 25 mm Stärke  
for 6 chopping boards up to 25 mm thickness  
para 6 tablas de corte de 25 mm  
pour 6 planches de 25 mm



	cm	↑ cm	€
88903	27 x 31	28	31,00



**Eiswaffel-Ständer**  
cornet stand  
soporte cucuruchos  
support à cornets

matt poliert, mit 4 Löchern, 2 x Ø 31 mm + 2 x Ø 26 mm  
matt polished, with 4 holes, 2 x Ø 31 mm + 2 x Ø 26 mm  
pulido mate, con 4 agujeros 2 x Ø 31 mm + 2 x Ø 26 mm  
poli mat, 4 trous - 2 x Ø 31 mm + 2 x Ø 26 mm



	cm	↑ cm	€
11881	27,5 x 9,5	9	20,90



**Eisportionierer**  
ice cream scoop  
cuchara para helado  
cuillère à glace

hochglanzpoliert, mit Edelstahlfeder (physikalisch bedingt nicht korrosionsbeständig)  
mirror polished, spring steel, spring is not stainless  
pulido brillante, muelle de acero especial, no resistente al óxido  
poli brillant, ressort acier spécial, non résistant à l'oxydation



	Ø cm	→ cm	ltr.	€
71006	6,5	23,5	1/12	11,60
71005	6,0	22,5	1/16	11,60
71004	5,5	22,0	1/20	11,60
71003	5,0	22,0	1/24	11,60
71002	5,0	21,5	1/30	11,60
71001	4,5	21,0	1/36	11,60



**Flambierbrenner**  
chefs blow torch  
soplete de cocina para flambear  
chalumeau de cuisine

mit handelsüblichem Feuerzeuggas auffüllbar, Flamme einstellbar bis ca. 1300° C,  
Brenndauer von mindestens 60 Minuten

to be filled with commercial lighter gas, flame adjustable up to approx. 1300° C,  
burning time of at least 60 minutes  
rellenable con gas de mechero comercial, llama ajustable hasta 1300° C,  
tiempo de combustión de al menos 60 minutos  
rempli avec gaz pour briquet commercial, flamme réglable jusqu'à 1300° C,  
temps de combustion d'au moins 60 minutes



	Ø cm	↑ cm	€
77315	4,5	16,5	33,00



Anwendungsbeispiel  
application example



## KITCHEN TOOLS



### Rezeptionsglocke

ring bell  
timbre  
sonnette



	Ø cm	↑ cm	€
71400	8,5	6,0	6,20
71433	10,0	6,5	7,80



### Bonspieß

bill spike  
pinchanotas  
pique-bons



Spieße aus flexiblem Kunststoff, mit stumpfen Enden zur Unfallverhütung

spikes made of flexible plastic, with blunt ends to prevent accidents

pinchos de plástico flexible

piques en plastique flexible

	cm	↑ cm	€
88855	9 x 5,5	10,5	3,80



### Bonleiste

bill rail  
portafichas  
barre porte-bons



Bonleiste matt poliert, mit Glaskugel-Greifsystem, zur Wandmontage geeignet, auch mit Magneten nutzbar, inklusive Befestigungsmaterial

bill rail matt polished, with glass ball gripping system, suited for wall fastening, can also be used with magnets, mounting material included

portafichas pulido mate, con sistema de agarre de bolas de cristal, apto para montaje en pared, también se puede utilizar con imanes, material de fijación incluido

barre porte-bons poli mat, avec système de préhension par billes de verre, adapté au montage mural, également utilisable avec des aimants, matériel de fixation inclus

barre porte-bons poli mat, avec système de préhension par billes de verre, adapté au montage mural, également utilisable avec des aimants, matériel de fixation inclus

	cm	↑ cm	€
88900	40 x 8	2	17,00
88901	50 x 8	2	18,40
88902	60 x 8	2	20,00



### Magnet-Messerhalter

magnetic knife rack  
barra magnética para cuchillos  
barre aimantée pour couteaux



mit 2 Magnetschiene und Haken, aus massivem Kunststoff, zur Wandmontage geeignet, Lieferung ohne Deko

with 2 magnet racks and hooks, strong plastic, suited for wall fastening

con 2 rails magnéticos y ganchos, plástico macizo, fijación en pared

avec 2 rails aimantés et crochets, plastique robuste, fixation murale

	→ cm	€
88911	45	11,20
88912	60	13,60



einhängbar  
hookable

**Panierstation, 3-teilig**

breeding set, 3 pcs. set  
estación de empanado, set de 3  
station de panure, set de 3

zum Panieren von Fleisch, Gemüse, Käse etc.

for breading meat, vegetables, cheese etc.

para empanar carne, verduras, queso, etc.

pour paner la viande, les légumes, le fromage etc.



	cm	↑ cm	€ / set
66904	45,5 x 18	2,5	14,00



**Zitronenschnitzelpresse**

lemon slice squeezer

pinza exprimelimón

pince presse citron

hochglanzpoliert, zum Auspressen von Zitronenscheiben / mirror polished, to press lemon slices / pulido brillante, para rodajas de limón / poli brillant, pour citrons en rondelle



	cm	€
71430	8 x 7	1,50



**Zitruspresse**

citrus squeezer

exprimidor cítricos

presse-citron

hochglanzpoliert, 2-teilig / mirror polished, 2 pcs. / pulido brillante, 2 piezas / poli brillant, 2 pièces



	∅ cm	↑ cm	ltr.	€
71431	12 / 17	10,5	0,35	13,80



88288

**Folien-Abreißvorrichtung**

clingfilm tear-off dispenser

dispensador de film

dérouleur de film

mit Abreißkante / Säge-Messer, für Endlosfolie, als Tischgerät oder Wandgerät verwendbar

with saw, for endless rolls, can be fixed on the wall

con sierra para rollo de film continuo, se puede fijar en la pared

avec lame dentée pour rouleau de film, peut être fixé au mur



	cm	↑ cm		€
88288	34 x 16	9	für Folienbreite 30 cm / for film width 30 cm para film ancho 30 cm / pour film largeur 30 cm	41,00
88287	49 x 16	9	für Folienbreite 45 cm / for film width 45 cm para film ancho 45 cm / pour film largeur 45 cm	46,00



63 cm

30 cm

klappbar  
folding

**Aufsteller „ACHTUNG RUTSCHGEFAHR“**

stand

letrero

panneau



	cm	↑ cm	€
71421	30 x 63	63	8,90