

COCINA KITCHEN



Download
Cutting
Catalogue

216



218 CORTE / STEAK KNIVES

- 218 TABLAS DE CORTE
- 222 PUNTILLAS
- 224 CUCHILLOS COCINA
 - 226 CARBON
 - 230 IBÉRICA
 - 232 MARBLE
 - 236 ZEN
 - 240 130
 - 242 MESTRE MAURICI
- 246 ACCESORIOS
- 254 RALLADORES Y ACCESORIOS DE CORTE
- 260 ESPÁTULAS

262 UTENSILIOS / UTENSILS

- 262 EMPLATADO
- 264 JUEGOS COCINA
 - 264 MONOBLOCK
 - 266 NYLON
- 274 PASTELERÍA

276 COCCIÓN / COOKING

- 280 SARTENES PROFESIONALES ALUMINIO
- 283 SARTENES PROFESIONALES INOX
- 284 GAMA CROSCAT
- 288 PAELLERAS
- 292 AMT
- 302 RISOLÍ

320 GASTRONORM

- 322 CUBERTAS GN AISI 304 - 18/10
- 326 CUBETAS GN INOX
- 331 CARROS

217

Cocina / Kitchen



Espesores de 2cm y 3cm.
2cm and 3cm Thicknesses.



Tacos antideslizantes de silicona para un mejor agarre en la superficie.
Silicone anti-slip pads for better grip on the surface.



Mayor rigidez. No se deforma con las altas temperaturas. Máx. 70°C
Higher rigidity, no deformation at high temperatures. Max. 70°C



Apto para contacto con alimentos.
Suitable for food contact.



Apto para lavavajillas.
Dishwasher safe.



Impermeable. No absorbe los líquidos.
SUPERFICIE AUTOCATRIZANTE
Más higiénica. Evita que se acumule suciedad y bacterias en los cortes.

Waterproof, does not absorb liquids.

AUTOHEAL SURFACE
More hygienic, prevents dirt and bacteria from accumulating in the cuts.



Corte / Tablas de corte Cutting / Cutting boards

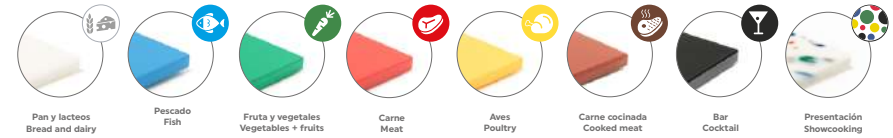

GN 1/1



GN 1/2

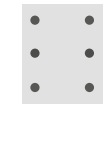

20x30cm



30x40cm

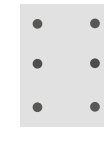

40x50cm

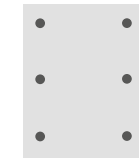

40x60cm



Tabla corte pan y lácteos blanca

White cutting board
Planche à découper blanche
Tagliere bianco
Wibes schneidebrett

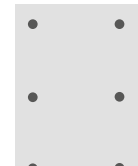

REF.	W _{mm}	L _{mm}	ESPESOR cm	TACOS	€	UE / MOQ
NEW 11756	GN 1/1	GN 1/1	3	6	54,44	1-0-4 / 1
8523	GN 1/2	GN 1/2	2	6	20,20	1-0-10-60-180 / 1
8525	300	200	2	4	13,66	1-0-10-60-180 / 1
8526	400	300	2	6	25,58	1-0-6-36-108 / 1
8527	500	300	2	6	32,81	1-0-6-36-108 / 1
NEW 11758	600	400	3	6	75,18	1-0-2 / 1

NEW

Tabla corte bar

Black cutting board
Planche à découper noir
Tagliere nero
Schwarzes schneinebrett



REF.	W,L cm	ESPESOR cm	TACOS	€	UE / MOQ
11760	30x20	2	4	13,66	1-0-5-30-90 / 1
11759	40x30	2	6	25,46	1-0-10-60-180 / 1



POLIETILENO 500 DE ALTA DENSIDAD DE ALTO PESO MOLECULAR(HD-HMW)
HIGH MOLECULAR WEIGHT HIGH DENSITY POLYETHYLENE 500 (HD-HMW)

NEW

Tabla corte presentación
Cutting board presentation
Présentation de la planche à découper
Presentazione del tagliere
Präsentation des Schneebrett



REF.	W.L. cm	ESPEJOR cm	TACOS	€	UE / MOQ
11998	30x20	2	4	25,09	1-0-8-0-0 / 1

Tabla corte pescado azul
Blue cutting board
Planche à découper bleu
Tagliere blue
Blau schneidebrett



REF.	W mm	L mm	ESPEJOR cm	TACOS	€	UE / MOQ
8529	GN 1/1	GN 1/1	2	6	35,19	1-0-5-30-90 / 1
8532	300	200	2	4	13,66	1-0-10-60-180 / 1
8533	400	300	2	6	26,25	1-0-6-36-108 / 1
8534	500	300	2	6	32,81	1-0-6-36-108 / 1
8535	600	400	2	6	52,53	1-0-4-24-72 / 1

Tabla corte fruta y vegetales verde
Green cutting board
Planche à découper vert
Tagliere verde
Grün schneidebrett



REF.	W mm	L mm	ESPEJOR cm	TACOS	€	UE / MOQ
8536	GN 1/1	GN 1/1	2	6	35,19	1-0-5-30-90 / 1
8539	300	200	2	4	13,66	1-0-10-60-180 / 1
8540	400	300	2	6	25,58	1-0-6-36-108 / 1
8541	500	300	2	6	32,81	1-0-6-36-108 / 1
8542	600	400	2	6	52,53	1-0-4-24-72 / 1

Tabla corte carne cruda roja
Red cutting board
Planche à découper rouge
Tagliere rosso
Rot schneidebrett



REF.	W mm	L mm	ESPEJOR cm	TACOS	€	UE / MOQ
8543	GN 1/1	GN 1/1	2	6	35,19	1-0-5-30-90 / 1
8546	300	200	2	4	13,66	1-0-10-60-180 / 1
8547	400	300	2	6	25,58	1-0-6-36-108 / 1
8548	500	300	2	6	32,81	1-0-6-36-108 / 1
8549	600	400	2	6	52,53	1-0-4-24-72 / 1



Tabla corte carne cruda aves amarilla
Yellow cutting board
Planche à découper jaune
Tagliere giallo
Gelb schneidebrett



REF.	W mm	L mm	ESPEJOR cm	TACOS	€	UE / MOQ
8550	GN 1/1	GN 1/1	2	6	35,19	1-0-5-30-90 / 1
8553	300	200	2	4	13,66	1-0-10-60-180 / 1
8554	400	300	2	6	25,58	1-0-6-36-108 / 1
8555	500	300	2	6	32,81	1-0-6-36-108 / 1
8556	600	400	2	6	52,53	1-0-4-24-72 / 1

Tabla corte carnes cocidas marrón
Brown cutting board
Planche à découper marron
Tagliere marrone
Braun schneidebrett



REF.	W mm	L mm	ESPEJOR cm	TACOS	€	UE / MOQ
8557	GN 1/1	GN 1/1	2	6	35,19	1-0-5-30-90 / 1
8560	300	200	2	4	13,66	1-0-10-60-180 / 1
8561	400	300	2	6	25,58	1-0-6-36-108 / 1
8562	500	300	2	6	32,81	1-0-6-36-108 / 1
8563	600	400	2	6	52,53	1-0-4-24-72 / 1

NEW

Soporte inox para tablas
Cutting board support
Support planche à découper
Supporto tagliere
Schneidebretthalterung



REF.	W mm	L mm	H mm	€	UE / MOQ
11640	265	310	280	20,71	1-0-20 / 1

NEW

Rascador para tabla
Cutting board scraper
Brosse pour planche à découper
Spazzola per tagliere
Reinigungsbürste für Schneidebrett



REF.	W mm	L mm	H mm	€	UE / MOQ
11761	60	170	90	38,44	1-0-36 / 1

NEW

Pack 6 tacos silicona
6 Pack rubber stoppers
Pack 6 tacos silicone
Confezione di 6 tacos in silicone
Pack 6 tacco-ständer silikon



REF.	TACOS	€	UE / MOQ
11941	6	3,26	1-0-1000 / 1

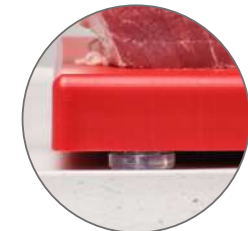

ACERO:
3Cr13



Cuchillo mult usos.
Micro serrated knife.



Cuchillo pelador.
Peeling knife.



Cuchillo chuletero.
Steak knife.



Cuchillo fruta micro.
Micro serrated fruit knife.

El 3Cr13MoV es un acero inoxidable sólido que ofrece una buena resistencia a la corrosión, dureza y de fácil afilado. Es ideal para aquellos que quieren un cuchillo de bajo mantenimiento y uso general. Se desempeña de manera óptima en las tareas típicas de corte.

3Cr13MoV is a solid stainless steel that offers good corrosion resistance, hardness and easy sharpening. It is ideal for those who want a low-maintenance, general-purpose knife. It performs optimally in typical cutting tasks.



sierra microdentada
micro toothed saw



Cuchillo mult usos micro
Micro serrated utility knife
Couteau multi-usage micro
Coltello multiuso micro
Universalmesser micro

REF.	H03A (mm)	L1(mm)	€	UE / MOQ
7537	100	09	3,20	1-24-240-7200-21600 / 24
8303	BLISTER 2 U.		7,20	1-0-24-360-1440 / 24



Cuchillo chuletero
Steak knife
Couteau steak
Coltello bistecca
Steakmesser

REF.	H03A (mm)	L1(mm)	€	UE / MOQ
7535	120	230	3,11	1-24-240-7200-21600 / 24
8301	BLISTER 2 U.		7,01	1-0-24-360-1440 / 24

sierra microdentada
micro toothed saw



Cuchillo fruta micro
Micro serrated fruit knife
Couteau à fruits micro
Coltello fruta micro
Universalmesser Obst micr

REF.	H03A (mm)	L1(mm)	€	UE / MOQ
7538	88	199	3,11	1-24-240-7200-21600 / 24
8304	BLISTER 2 U.		7,01	1-0-24-360-1440 / 24



Cuchillo pelador
Peeling knife
Couteau à éplucher
Coltello spellucchino
Schälmesser

REF.	H03A (mm)	L1(mm)	€	UE / MOQ
7536	80	195	2,96	1-24-240-7200-21600 / 24
8302	BLISTER 2 U.		6,73	1-0-24-360-1440 / 24

Cuchillo chuletero
Steak knife
Couteau steak
Coltello bistecca
Steakmesser

REF.	H03A (mm)	L1(mm)	€	UE / MOQ
11585	120	230	3,11	1-0-24-360-1440 / 24

Cuchillo mult usos micro
Micro serrated utility knife
Couteau multi-usage micro
Coltello multiuso micro
Universalmesser micro

REF.	H03A (mm)	L1(mm)	€	UE / MOQ
11587	100	09	3,20	1-0-24-360-1440 / 24

Cuchillo pelador
Peeling knife
Couteau à éplucher
Coltello spellucchino
Schälmesser

REF.	H03A (mm)	L1(mm)	€	UE / MOQ
11586	80	195	2,96	1-0-24-360-1440 / 24





PUNTILLA / MONDADOR / UTILITY

Versátil, tanto para fruta y verdura, como para piezas pequeñas de carne. Versatile, both for fruit and vegetables, as well as for small pieces of meat.



PELADOR / VERDURAS / PEELING

Para trabajos pequeños y delicados. For small and delicate jobs.



DESHUESADOR / WRECKER

Su forma permite acceder a la carne y retirar huesos y tendones sin perder la forma. Its shape allows access to the flesh and the removal of bones and tendons without losing its shape.



JAMONERO / SLICER

Indicado para cortar jamón y carnes curadas. Suitable for cutting ham and cured meats.



SALMÓN / SALMON KNIFE

Hoja fina y alargada, con alvéolos para evitar que la carne se adhiera a la hoja. Thin, elongated blade, with sockets to prevent meat from sticking to the blade.



PANERO / BREAD KNIFE

Hoja dura y dentada que permite cortar alimentos con el exterior rígido con facilidad. Hard, serrated blade for easy cutting of food with a rigid exterior.



HACHA / CLEAVER

Hoja grande y gruesa que se utiliza para cortar y desosar carne cruda o cocinada. A large, thick blade used for cutting and boning raw or cooked meat.



FILETADOR / SLICER

Hoja larga y flexible que permite preparar carne y pescado con precisión. Long, flexible blade for precise meat and fish preparation.



SANTOKU / SANTOKU

Versión japonesa del cuchillo chef, ideal para preparar carne, pesca y verduras. Japanese version of the chef's knife, ideal for preparing meat, fish and vegetables.



CHEF / CHEF

El más popular de los cuchillos, con hoja grande y resistente sirve para todo tipo de cortes. The most popular of the knives, with a large, sturdy blade for all types of cutting.

La gama de productos de corte Comas, ha sido creada y mejorada para ofrecer a los cocineros y jefes de cocina, una amplia variedad de utensilios y cuchillos para corte que garantizan la calidad y durabilidad necesaria para el día a día de las cocinas profesionales.

The Comas range of cutting products has been created and improved to offer chefs and wide variety of cutting utensils and knives that guarantee the quality and durability necessary for everyday use in professional kitchens.



COLECCIÓN
COLLECTION

GRANITE	IBERICA	MARBLE	ZEN	130	MAURICI
---------	---------	--------	-----	-----	---------



MATERIAL	X50 Cr Mo V15	X50 Cr Mo V15	DIN 1.4116	AUS 8 SANMAI	AUS 10 SANMAI	CARBON STEEL 52100
DUREZA DE LA HOJA BLADE HARDNESS	HRC55 ± 5	HRC55 ± 5	HRC55 ± 2	HRC58 ± 2	HRC60 ± 1	HRC62 ± 2
MANGO HANDLE	POLIPROPILENO	POLIPROPILENO	ABS	PM	MADERA DE ÉBANO EBONY WOOD	ABEDUL ESTABILIZADO ABEDUL ESTABILIZADO
ORIGEN MATERIA PRIMA RAW MATERIAL ORIGIN	ALEMANIA GERMANY	ALEMANIA GERMANY	ALEMANIA GERMANY	CHINA CHINA	JAPÓN JAPAN	JAPÓN JAPAN
LAVAVAJILLAS DISHWASHER	✓	✓	✗	✗	✗	✗

El afilado de las hojas hecho manualmente. Garantiza un afilado perfecto y duradero.

Blades sharpening is carried out manually. Guarantee a perfect and durable sharpening.

La forma convexa de la hoja en ambas caras otorga a la hoja un grosor más continuado hasta el filo, garantizando una mayor firmeza en el corte. El pulido asegura un acabado liso e impecable.

The convex line of the blade on both sides grants the blade a more skiving continuing thickness up to the edge, ensuring a steadfast cutting. The polishing ensures a flawless flattening and finishing.

Alta calidad en el corte
 Resistencia a la corrosión

Strong cutting ability
 Resistant to corrosion.



Sello de calidad del fabricante y su compromiso de durabilidad y fiabilidad del producto.

Manufacturer's seal of quality and commitment to product durability and reliability.

TechFlex: Polímeros de PP con EVA para más sensibilidad, adherencia, confort y disminución de fatiga.

TechFlex: Polymers of PP with EVA for a more sensitivity, adhesion, comfort and decreased fatigue

Mangos ergonómicos y antideslizantes para una mayor sujeción.

Ergonomic, non-slip handles for a better grip.



El X50CrMoV15 es un excelente acero inoxidable de gama media que ofrece un rendimiento completo en cuchillos de cocina y cuchillos multiusos con una gran resistencia a la corrosión y una buena retención del filo. Es fácil de afilar, por lo que es ideal para aquellos que prefieren cuchillos de bajo mantenimiento que se pueden mantener afilados sin necesidad de un afilado profesional.

X50CrMoV15 is an excellent mid-range stainless steel that offers all-round performance in kitchen knives and utility knives, with high corrosion resistance and good edge retention. It is easy to sharpen, making it ideal for those who prefer low maintenance knives that can be kept sharp without the need for professional sharpening.



- 10074
- 10093
- 10104
- 10114
- 10128

Cuchillo chef 180
 Chef knife 180
 Couteau de cuisine 180
 Coltello chef 180
 Kochmesser 180

17,66 €

UE / MOQ:
 1-12-144-576-1728 / 12



- 10075
- 10094
- 10105
- 10115
- 10129

Cuchillo chef 200
 Chef knife 200
 Couteau de cuisine 200
 Coltello chef 200
 Kochmesser 200

21,55 €

UE / MOQ:
 1-12-72-288-864 / 12



- 10076
- 10095
- 10106
- 10116
- 10130

Cuchillo chef 250
 Chef knife 250
 Couteau de cuisine 250
 Coltello chef 250
 Kochmesser 250

23,68 €

UE / MOQ:
 1-12-72-288-864 / 12



- 10077
- 10096
- 10107
- 10117
- 10131

Cuchillo chef 300
 Chef knife 300
 Couteau de cuisine 300
 Coltello chef 300
 Kochmesser 300

28,68 €

UE / MOQ:
 1-6-48-192-576 / 6



- 10078 Cuchillo deshuesador 140
- 10097 Wrecker knife 140
- 10108 Couteau de desossage 140
- 10118 Coltello disossato 140
- 10118 Ausbeinmesser 140

11,71 € UE / MOQ:
 1-12-144-576-1728 / 12



- 10079 Cuchillo carnicero 160
- 10098 Butcher knife 160
- 10109 Couteau boucher 160
- 10119 Coltello scannare 160
- 10119 Fleischermesser 180

13,46 € UE / MOQ:
 1-12-144-576-1728 / 12



- 10084 Cuchillo pan y pastelero 250
- 10127 Bread and pastry knife 250
- 10127 Couteau à pain et pâtisserie 250
- 10127 Coltello pane 250
- 10127 Brotmesser 250

16,66 € UE / MOQ:
 1-12-72-288-864 / 12



- 10080 Cuchillo carnicero 180
- 10099 Butcher knife 180
- 10110 Couteau boucher 180
- 10120 Coltello scannare 180
- 10120 Fleischermesser 180

15,37 € UE / MOQ:
 1-12-144-576-1728 / 12



- 10085 Cuchillo para fiambres 300
- 10124 Slicing knife 300
- 10124 Couteau à charcuterie 300
- 10124 Coltello affettati 300
- 10124 Tranchiermesser 300

20,67 € UE / MOQ:
 1-6-48-192-576 / 6



- 10081 Cuchillo carnicero 200
- 10100 Butcher knife 200
- 10111 Couteau boucher 200
- 10121 Coltello scannare 200
- 10121 Fleischermesser 200

18,27 € UE / MOQ:
 1-12-72-288-864 / 12



- 10086 Cuchillo salmón 300
- 10103 Salmon knife 300
- 10103 Couteau saumon 300
- 10125 Coltello salmone 300
- 10125 Lachsmesser 300

27,91 € UE / MOQ:
 1-6-48-192-576 / 6



- 10082 Cuchillo carnicero 240
- 10101 Butcher knife 240
- 10112 Couteau boucher 240
- 10122 Coltello scannare 240
- 10122 Fleischermesser 240

22,88 € UE / MOQ:
 1-12-72-288-864 / 12



- 10087 Cuchillo jamonero 280
- 10126 Ham knife 280
- 10126 Couteau à jambon 280
- 10126 Coltello prosciutto 280
- 10126 Schinkenmesser 280

18,65 € UE / MOQ:
 1-6-48-192-576 / 6



- 10083 Cuchillo carnicero 300
- 10102 Butcher knife 300
- 10113 Couteau boucher 300
- 10123 Coltello scannare 300
- 10123 Fleischermesser 300

26,69 € UE / MOQ:
 1-6-48-192-576 / 6



- 10092 Cuchillo chuletero 130
- 10092 Steak knife 130
- 10092 Couteau à steak 130
- 10092 Coltello per bistecca 130
- 10092 Steakmesser 130

6,79 € UE / MOQ:
 1-12-60-240-720 / 12



Ideal para cortar o filetear.
Ideal for slicing or filleting.

Mango ergonómico
y antideslizante.
Ergonomic, non-slip
handle.

HIGH CARBON
NO STAIN
X50 CrMo V15
Made in Portugal

comas
DESIGNING THE EVERYDAY

Hoja de bajo espesor que
lo hace ligero y facilita el
manejo.
Thin blade makes it light
and easy to handle.

Los cuchillos de la línea IBÉRICA al igual que GRANITE, están fabricados en acero X50 CrMo V15 y pueden ser utilizados para cortar o filetear gracias a su fino espesor. Esta gama presenta un mango moderno, ergonómico y antideslizante que garantiza un mayor confort y seguridad en su uso.

The knives of the IBÉRICA line, like GRANITE, are made of X50 CrMo V15 steel and can be used for cutting or filleting thanks to their thin thickness. This range has a modern, ergonomic and non-slip handle that guarantees greater comfort and safety in use.



Macheta 180
Cleaver 180
Couperet 180
Mannaietta 180
Hackmesser 180

REF.	H2A (mm)	Lj (mm)	€	UE / MOQ
● 10088	180/7"	300	44,24	1-12-12-48-144 / 12



Hachuela 250
Cleaver 250
Couperet 250
Mannaietta 250
Hackmesser 250

REF.	H2A (mm)	Lj (mm)	€	UE / MOQ
● 10089	250/10"	345	68,41	1-12-12-48-144 / 12



Macheta filetera 220
Fillets cleaver 220
Couperet filet 220
Mannaietta per affettare 220
Filetirmesser 220

REF.	H2A (mm)	Lj (mm)	€	UE / MOQ
● 10090	220/8'6"	315	30,05	1-6-6-24-72 / 6



Macheta filetera 280
Fillets cleaver 280
Couperet filet 280
Mannaietta per affettare 280
Filetirmesser 280

REF.	H2A (mm)	Lj (mm)	€	UE / MOQ
● 10091	280/11"	362	34,70	1-6-6-24-72/6

ACERO:
GERMAN
STEEL
DIN 1.4116

DUREZA:
HRC55 ± 2



La colección Marble está creada por 12 cuchillos exclusivos. Están realizados en acero alemán que garantiza la calidad por su alta resistencia. Este conjunto, caracterizado por su diseño funcional, destaca por su elegante color blanco. El aliado perfecto para cualquier profesional de la cocina

The Marble collection consists of 12 exclusive knives. They are made of German steel, which guarantees quality and high resistance. This set, characterised by its functional design, stands out for its elegant white colour. The perfect ally for any kitchen professional.



El acero alemán DIN 1.4116 es reconocido por su calidad excepcional y versatilidad, que lo convierte en uno de los materiales preferidos en la fabricación de cuchillos.

Su composición equilibrada ofrece una resistencia superior al desgaste y la oxidación, esto significa que mantienen el filo durante más tiempo y resisten un uso intensivo, algo esencial para los chefs.

German DIN 1.4116 steel is renowned for its exceptional quality and versatility, making it one of the preferred materials in knife making.

Its balanced composition offers superior resistance to wear and oxidation, which means it holds its edge longer and withstands intensive use - essential for chefs.



FILO: Afilado en "V" para una mejor precisión en el corte.

EDGE: With "V"-grind for a finer cut.

HOJA: Fabricado con acero alemán de alta calidad: DIN1.4116 HRC55 ± 2.

BLADE: Made with high-quality German steel: DIN1.4116 HRC55 ± 2.

Proceso de endurecimiento de la hoja en frío para un afilado duradero y resistente al óxido.

Cold-hardened blade for a long-lasting, rust-free grind.

REFUERZO: Cabezal cónico para un agarre cómodo y seguro.

REINFORCEMENT: Cone-shaped bolster for a comfortable, secure grip.

MANGO: Diseño ergonómico para un mejor agarre, proporcionando el equilibrio perfecto en la sujeción del cuchillo.

HANDLE: Ergonomically designed for better grip, giving perfect balance in the hand.

Remaches resistentes a la corrosión. Fabricado en ABS, le proporciona una mayor dureza y una alta resistencia al calor.

Rust-resistant rivets. Made from boron steel which makes it tougher and more heat resistant.

Talón acabado en acero inoxidable que proporciona protección y mayor robustez al mango.

Butt finished in stainless steel to provide protection and make the handle more durable.



Cocina / Kitchen
MARBLE COLLECTION

ACERO:
GERMAN
STEEL
DIN 1.4116

DUREZA:
HRC55±2



Cuchillo chef 20
Chef knife 20
Couteau de cuisine 20
Coltello chef 20
Kochmesser 20

REF.	H30A (mm)	L (mm)	€	UE / MOQ
8108	200/8"	320	29,43	1-6-36-144-432 / 6



Cuchillo chef 25
Chef knife 25
Couteau de cuisine 25
Coltello chef 25
Kochmesser 25

REF.	H30A (mm)	L (mm)	€	UE / MOQ
8117	250/10"	380	30,90	1-6-36-216-432 / 6



Cuchillo mini Santoku
Mini Santoku knife
Couteau mini Santoku
Coltello mini Santoku
Mini Santoku-Messer

REF.	H30A (mm)	L (mm)	€	UE / MOQ
8112	115/4,5"	230	18,33	1-6-48-288-576 / 6



Cuchillo verduras
Utility knife
Couteau à légumes
Coltello multiuso
Universalmesser

REF.	H30A (mm)	L (mm)	€	UE / MOQ
8113	125/5"	230	15,93	1-6-48-288-576 / 6



Cuchillo fileteador
Carving knife
Couteau à filet
Coltello per affettare
Tranchiermesser

REF.	H30A (mm)	L (mm)	€	UE / MOQ
8109	200/8"	320	23,26	1-6-36-144-432 / 6



Cuchillo panero
Bread knife
Couteau à pain
Coltello pane
Brotmesser

REF.	H30A (mm)	L (mm)	€	UE / MOQ
8110	200/8"	320	23,69	1-6-36-144-432 / 6



Cuchillo chuletero
Steak knife
Couteau à steak
Coltello per bistecca
Steakmesser

REF.	H30A (mm)	L (mm)	€	UE / MOQ
8114	115/4,5"	220	15,93	1-6-48-288-576 / 6



Cuchillo Mondador
Paring knife
Couteau d'office
Coltello sbucciatore
Schälmesser

REF.	H30A (mm)	L (mm)	€	UE / MOQ
8115	80/3,5"	190	15,93	1-6-48-288-576 / 6



Cuchillo Santoku
Santoku knife
Couteau Santoku
Coltello Santoku
Santoku-Messer

REF.	H30A (mm)	L (mm)	€	UE / MOQ
8111	165/6,5"	300	29,57	1-6-36-144-432 / 6



Cuchillo jamonero
Slicing knife
Couteau à jambon
Coltello da prosciutto
Schinkenmesser

REF.	H30A (mm)	L (mm)	€	UE / MOQ
8116	260/9,5"	385	24,69	1-6-36-144-432 / 6



Cuchillo deshuesador
Boning knife
Couteau de désossage
Coltello dissosato
Ausbeinmesser

REF.	H30A (mm)	L (mm)	€	UE / MOQ
8118	155/7,8"	280	20,34	1-6-36-216-432 / 6



Chaira
Sharpening steel
Fusil
Acciaini
Wetzstahl

REF.	H30A (mm)	L (mm)	€	UE / MOQ
8119	205/7,8"	325	12,43	1-6-36-216-432 / 6



La colección de cuchillos ZEN está diseñada para perdurar en el tiempo. Se caracteriza por su diseño elegante y minimalista que refleja la estética japonesa convirtiéndola en una pieza tradicional, innovadora e imprescindible para complementar cualquier cocina.

Esta colección es ideal para aquellos que buscan calidad, rendimiento y belleza en una sola herramienta. El filo tiene un excelente afilado que facilita el corte preciso de cualquier ingrediente.

The ZEN knife collection is designed to last over time. It is characterised by its elegant and minimalist design that reflects Japanese aesthetics, making it a traditional, innovative and essential piece to complement any kitchen.

This collection is ideal for those looking for quality, performance and beauty in a single tool. The cutting edge has an excellent sharpness that facilitates the precise cutting of any ingredient.

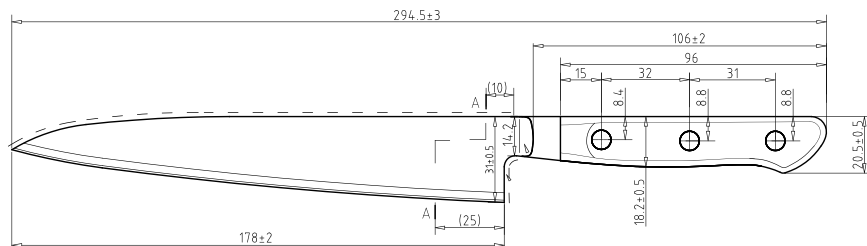

ACERO SAN MAI 3 CAPAS
SAN MAI STEEL 3 LAYERS

Exterior:
Acero inoxidable al cromo 13

Outer layers:
13 chrome stainless steel.

Núcleo:
Acero de aleación (AUS8)

Core: Alloy steel (AUS8)

Diseño ergonómico para un mejor agarre. Acabado suave y satinado.

Ergonomic design for a better grip.

SAN MAI, significa "3 capas" en japonés y es una técnica tradicional de forjado de cuchillos que consiste en la combinación de diferentes tipos de acero con en una estructura laminada, con el fin de aprovechar las mejores características de cada material.

NÚCLEO: El AUS-8 es una opción versátil para los cuchillos de acero inoxidable. Es un acero con un rendimiento sólido.

EXTERIOR: A ambos lados del núcleo encontramos un acero más suave y resistente a la corrosión, protegiendo el núcleo de impactos y roturas.



Afilado en "V" para una mejor precisión en el corte.

With V-grind for a finer cut.

Virola 18/10 con estructura de espiga completa.

18/10 Ferrule full tang structure.

SAN MAI, which means '3 layers' in Japanese, is a traditional knife forging technique that consists of combining different types of steel in a laminated structure, in order to take advantage of the best characteristics of each material.

CORE: AUS-8 is a versatile choice for stainless steel knives. It is a steel with a solid performance.

EXTERIOR: On both sides of the core is a softer, corrosion resistant steel, protecting the core from impact and breakage.

Cocina / Kitchen
ZEN COLLECTION

ACERO:
AUS8

DUREZA:
HRC 58±2

POM
PLASTIC
MANGO



NEW

Corte / Cuchillos de cocina
Cutting / Kitchen knives



PACKAGING
BOX

Cuchillo santoku
Santoku zen knife
Couteau santoku
Coltello santoku
Santoku-Messer

REF.	H03A (mm)	L (mm)	€	UE / MOQ
10968	165	295	61,82	1-6-36-0-0 / 1



Cuchillo puntilla
Peeling knife
Couteau éplucheur
Coltello da cucina professionale
Schälmesser

REF.	H03A (mm)	L (mm)	€	UE / MOQ
10964	90	205	33,85	1-6-36-0-0 / 1



Cuchillo fileteador
Slice knife
Couteau tranche
Coltello fetta
Tranchiermesser

REF.	H03A (mm)	L (mm)	€	UE / MOQ
10966	180	290	59,05	1-6-36-0-0 / 1



Cuchillo verduras
Vegetable knife
Couteau à légumes
Coltello per verdure
Gemüsemesser

REF.	H03A (mm)	L (mm)	€	UE / MOQ
10965	145	275	38,49	1-6-36-0-0 / 1



Cuchillo chef
Chef's knife
Couteau chef
Coltello chef
Küchenmesser

REF.	H03A (mm)	L (mm)	€	UE / MOQ
10967	210	335	67,36	1-6-36-0-0 / 1



Cuchillo nakiri
Nakiri knife
Couteau nakiri
Coltello nakiri
Nakiri messer

REF.	H03A (mm)	L (mm)	€	UE / MOQ
10969	165	295	67,22	1-6-36-0-0 / 1



Cuchillo fileteador
Sharpening steel
Fusil
Acciaini
Tranchiermesser

REF.	H03A (mm)	L (mm)	€	UE / MOQ
10970	240	365	86,04	1-6-36-0-0 / 1

Cuchillo chef
Chef's knife
Couteau chef
Coltello chef
Küchenmesser



REF.	H2A(mm)	L(mm)	€	UE / MOQ
11022	210MM	365	144,38	1-0-0-0-0 / 1

Cuchillo fileteador
Carving knife
Couteau à filet
Coltello sfilettatore
Filetmesser



REF.	H2A(mm)	L(mm)	€	UE / MOQ
11605	235MM	385MM	134,67	1-0-0-0-0 / 1

Cuchillo Puntilla
Paring Knife
Couteau À Pointe
Coltello Da Cucina Professionale
Ausbeinmesser



REF.	H2A(mm)	L(mm)	€	UE / MOQ
11024	100MM	213MM	84,01	1-0-0-0-0 / 1

Cuchillo Fileteador
Carving Knife
Couteau À Filet
Coltello Sfilettatore
Filetmesser



REF.	H2A(mm)	L(mm)	€	UE / MOQ
11023	180MM	320MM	131,62	1-0-0-0-0 / 1

Cuchillo Kiritsuke
Kiritsuke Knife
Couteau Kiritsuke
Coltello Kiritsuke
Kiritsuke-Messer



REF.	H2A(mm)	L(mm)	€	UE / MOQ
11606	170MM	313MM	144,38	1-0-0-0-0 / 1



PIN
Mosaico de la familia UTSET con sus cuatro puntos generacionales.
Mosaic of the UTSET family with its four generational points.



PACKAGING BOX



HOJA / BLADE
Acero japonés
SANMAI AUS10
Dureza 60 1 HRC

Japanese steel
SANMAI AUS10
Hardness 60 1 HRC

VIROL / FERRULE
Diseñada para distintos agarres.
Anillo de raíz estabilizada.

Designed for different grips.stabi-
lised root ring.

MANGO / HANDLE
Cuerpo de madera
de ébano.

Ebony wood body.

El acero japonés AUS10 destaca como una opción versátil y de alta calidad entre los aceros japoneses para cuchillos.

Japanese AUS10 stands out as a versatile and high quality choice among Japanese knife steels.

Con una dureza notable que oscila entre 58 y 60 HRC y un contenido en cromo de aproximadamente el 13%, este acero ofrece una excelente resistencia a la corrosión, garantizando una larga durabilidad y rendimiento.

With a remarkable hardness ranging from 58 to 60 HRC and a chromium content of approximately 13%, this steel offers excellent corrosion resistance, ensuring long durability and performance.

Cuchillo Panero
Bread knife
Couteau à pain
Coltello da pane
Brotmesser

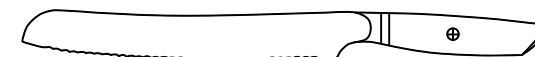

REF.	H2A(mm)	L(mm)	€	UE / MOQ
12020	235MM	385MM	112,50	1-0-0-0-0 / 1

Tenedor Trinchador
Carving fork
Fourchette à découper
Forchetta da intaglio
Tranchiergabel

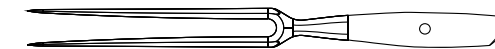

REF.	H2A(mm)	L(mm)	€	UE / MOQ
12021	160MM	306MM	62,50	1-0-0-0-0 / 1

Acero de carbono

El 52100 es un acero al cromo con alto contenido en carbono que ha ganado popularidad en el mundo de la cuchillería para hojas de alto rendimiento.

Conocido por su excepcional dureza, resistencia al desgaste y retención del filo, se utiliza a menudo en cuchillos personalizados de gama alta que requieren una durabilidad superior.

Al ser un cuchillo no inoxidable, se le ha aplicado una pátina negra en toda la hoja para evitar que se oxide fácilmente. Aún así aconsejamos lavarlo siempre a mano y secarlo rápido.

Si se guarda durante tiempo es aconsejable untar de aceite mineral la hoja y la espiga así como guardarlo protegido con funda o saya.

Carbon steel

52100 is a high-carbon chrome steel that has gained popularity in the world of high-performance knife making.

Known for its exceptional hardness, wear resistance and edge retention, it is often used in high-end custom knives that require superior durability.

As a non-stainless knife, a black patina has been applied to the entire blade to prevent it from rusting easily. Even so, we advise to always wash it by hand and dry it quickly.

If it is stored for a long time, it is advisable to smear mineral oil on the blade and tang and to keep it protected with a saya.



Raíz de abedul estabilizada

El mango, de raíz de abedul estabilizada proporciona a la colección la elegancia de una madera noble.

El proceso de estabilización protege y sella la porosidad de la madera para garantizar una mayor durabilidad y resistencia, además de resultar muy agradable al tacto.

Aún siendo un material duradero y resistente es importante evitar el lavavajillas y mantener siempre el cuchillo seco.

Stabilised birch root

The handle, made of stabilised birch root, gives the collection the elegance of a noble wood.

The stabilisation process protects and seals the porosity of the wood to ensure greater durability and strength, as well as being very pleasant to the touch.

Yet being a durable and resistant material, it is important to avoid dishwashing and to always keep the knife dry.



PACKAGING
 BOX

Conoce UTSET en la página: 494
 More about UTSET in page: 494



Corte / Cuchillos de cocina Cutting / Kitchen knives

KISSAKI

La punta de la hoja. Puede variar de forma según el tipo de cuchillo. Se utiliza el realizar cortes en carnes y pescado o en esculpir verduras

The tip of the blade. It can vary in shape depending on the type of knife. Used for cutting meat and fish or carving vegetables.

HASAKI

Parte afilada que se convierte en el filo del cuchillo.

The sharp part that becomes the cutting edge of the knife.

Hoja fabricada con acero al carbono, conocido por su capacidad de mantener un filo excepcional y su facilidad para ser afilados.

Blade made of carbon steel, known for its ability to maintain an exceptional sharpness and ease of sharpening.

HAMOTO

Parte del filo cerca del mango. Al cortar pescado crudo para hacer sashimi, normalmente se corta desde el hamoto.

Part of the blade near the handle. When cutting raw fish for sashimi, it is usually cut from the hamoto.

KIREHA

Parte final de la hoja, normalmente con forma curva para facilitar el agarre del cuchillo.

The end of the blade, usually curved to make it easier to grip the knife.

PASADOR PIN MOSAICO

Con 4 puntos de acero que representan las 4 generaciones con 130 años de experiencia y pasión por los cuchillos

With 4 steel points representing the 4 generations with 130 years of experience and passion for knives.

MINE

Columna vertebral de la hoja. Parte opuesta al filo.

Spine of the blade. The part opposite the blade.

AGO

Parte más ancha y gruesa de la hoja. Se usa para tareas que requieren más precisión, como cortar alimentos más duros.

The wider, thicker part of the blade. Used for tasks requiring more precision, such as cutting harder foods.

E

Cuerpo principal del mango.

Main body of the handle.

Mango fabricado con raíz de abedul estabilizada. Muy agradable al tacto y mucho más resistente al lavado.

Handle made of stabilised birch root. Very pleasant to the touch and much more resistant to washing.



Cuchillo Chef
Chef's knife
Couteau chef
Coltello chef
Küchenmesser



REF.	HCSA (mm)	L (mm)	€	UE / MOQ
11608	215MM	351MM	97,08	1-0-0-0-0- /1

Cuchillo Fileteador
Slicer
Couteau à filet
Coltello sfilettatore
Filetierre



REF.	HCSA (mm)	L (mm)	€	UE / MOQ
11609	185MM	312MM	84,68	1-0-0-0-0- /1

Cuchillo Puntilla
Utility knife
Couteau à pointe
Coltello da cucina
Ausbeinmesser



REF.	HCSA (mm)	L (mm)	€	UE / MOQ
11610	100MM	212MM	66,97	1-0-0-0-0- /1

Cuchillo Fileteador
Slicer
Couteau à filet
Coltello sfilettatore
Filetierre



REF.	HCSA (mm)	L (mm)	€	UE / MOQ
11657	235MM	367MM	96,56	1-0-0-0-0- /1

Cuchillo Kiritsuke
Kiritsuke knife
Couteau Kiritsuke
Coltello Kiritsuke
Kiritsuke-Messer



REF.	HCSA (mm)	L (mm)	€	UE / MOQ
11658	170MM	300MM	86,75	1-0-0-0-0- /1

Cuchillo Verduras
Petty knife
Couteau à légumes
Coltello per verdure
Gemüsemesser



REF.	HCSA (mm)	L (mm)	€	UE / MOQ
11659	150MM	265MM	78,85	1-0-0-0-0- /1

Cuchillo Santoku
Santoku Knife
Couteau Santoku
Coltello Santoku
Santoku-Messer



REF.	HCSA (mm)	L (mm)	€	UE / MOQ
11660	170MM	302MM	87,78	1-0-0-0-0- /1



Funda Saya Madera
Saya wooden sheath
Étui en bois saya
Custodia saya in legno
Holzkiste saya

REF.	CUCHILLO / KNIFE	L (mm)	€	UE / MOQ
11083	CHEF	215	17,19	1-12-120-0-0 /1
11084	FILETEADOR	185	15,53	1-12-120-0-0 /1
11085	PUNTILLA	150	12,31	1-12-120-0-0 /1
11086	FILETEADOR	235	17,19	1-12-120-0-0 /1
11087	KIRITSUKE	170	15,80	1-12-120-0-0 /1
11088	VERDURAS	150	13,20	1-12-120-0-0 /1
11661	SANTOKU	170	15,25	1-12-120-0-0 /1



Madera de acacia de alta calidad.
High quality acacia wood.

4 lados magnéticos.
4 magnetic sides.

Base de acero inoxidable con almohadillas antideslizantes.
Stainless steel base with non-slip pads.

Giratorio 360°
360° rotatable



NEW

Iman Taco Rotable Cuchillos
Rotating Magnet Knife Display
Aimant Taco Rotatif Pour Couteaux
Barra Magnetica Taco Rotabile Coltelli
Drehbarer Tischmagnet für Messer



REF.	L(mm)	W(mm)	H(mm)	€	UE / MOQ
11636	105	105	280	55,70	1-0-4-0-0 / 1



NEW

Iman Sobremesa Cuchillos
Tabletop Magnet Knife Display
Aimant De Table Pour Couteaux
Barra Magnetica Portacoltelli
Tischmagnet für Messer



REF.	L(mm)	W(mm)	H(mm)	€	UE / MOQ
11038	90	280	245	51,56	1-0-5-0-0 / 1



NEW

Expositor Madera Cuchillo Chef
Wooden Chef'S Knives Display
Éspositor En Bois Pour Couteau De Chef
Espositor In Legno Coltelli Chef
Messerhalter für Küchenmesser



REF.	L(mm)	W(mm)	H(mm)	€	UE / MOQ
11637	340	80	180	28,13	1-0-10-0-0 / 1



Imán pared madera
Wooden wall magnet
Porte-couteaux magnetic
Barra magnetica legno
Magnetleiste für Messer Holz



REF.	L(mm)	H(mm)	€	UE / MOQ
8471	460	67	39,19	1-0-8-88-264 / 6



Imán pared inox
Magnetic bar inox
Porte-couteaux magnetic inox
Barra magnetica inox
Magnetleiste für Messer inox



REF.	L(mm)	H(mm)	€	UE / MOQ
8470	350	47	35,89	1-6-8-144-288 / 6



Imán pared PP
PP magnetic bar
Porte-couteaux magnetic PP
Barra magnetica PP
Magnetleiste für Messer PP



REF.	L(mm)	H(mm)	€	UE / MOQ
8472	550	50	13,36	1-6-12-108-432 / 6



Madera de acacia de alta calidad.
High quality acacia wood.

Tratada con aceites naturales para resaltar su color y protegerla de la humedad.

Treated with natural oils to enhance its colour and protect it from moisture.

Grosor considerable para mayor durabilidad y estabilidad.

Substantial thickness for durability and stability.

El patrón de bolques END GRAIN ofrece mayor resistencia al desgaste y menor daño a los cuchillos.

The END GRAIN bolt pattern offers greater wear resistance and less damage to knives.



Hendiduras laterales para el agarre. Facilitan el levantamiento y transporte, incluso cargada con alimentos.

Side grooves for gripping and easy lifting and transport, even when loaded with foodstuffs.

Tacos de goma antideslizantes. Colocados en las esquinas, evitan que la tabla se deslice durante su uso, proporcionando estabilidad.

Non-slip rubber pads on the corners prevent the board from slipping during use and provide stability.



Tabla madera acacia
Acacia wood board
Planche en bois d'acacia
Tavola in legno di acacia
Akazienholzplatte



REF.	W(mm)	L(mm)	H(mm)	€	UE / MOQ
12034	400	320	38	55,00	1-0-0 / 1

Ideal para mantener la piedra fija durante el proceso de afilado.

Ideal for holding the stone in place during the sharpening process.

Soporte de caucho ajustable a distintos tamaños de piedras.

Adjustable rubber support for different stone sizes.

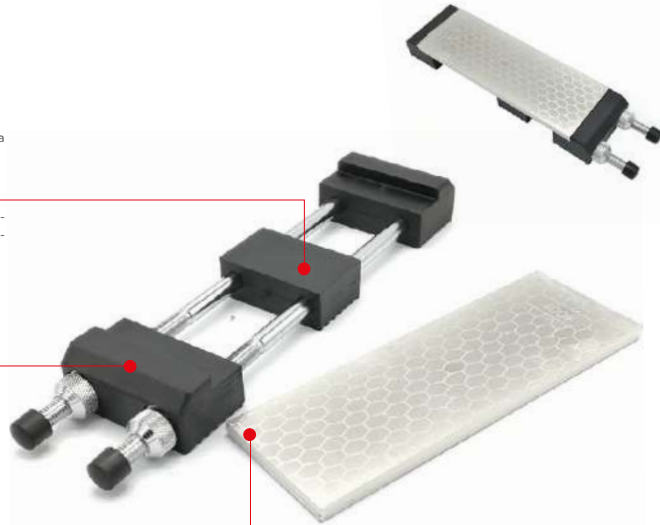

Placa diamantada de doble cara (grano 400 / 1000) y doble función: reparación de hojas dañadas y realizar un filo completamente nuevo. También la podemos usar para aplanar y limpiar las piedras de afilar usadas.

Double-sided diamond plate (grit 400/1000) with double function: repairing damaged blades and making a completely new cutting edge. It can also be used to flatten and clean used whetstones.

NEW

Placa diamantada para afilado con soporte

Diamond encrusted sharpening and levelling stone with stand
Plaque diamantée pour affûtage et aplatissage avec support
Piastra diamantata per affilare e appiattare con supporto
Diamantschleifstein mit Haltern

REF.	L(mm)	W(mm)	H(mm)	€	UE / MOQ
11939	286	70	30	41,80	1-0-10-0-0 / 1

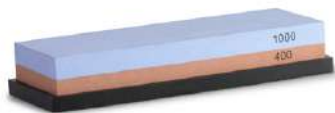

Piedra afilar

Whetstone
Pierre à aiguiser
Cote
Schärfstein Messer

REF.	L(mm)	€	UE / MOQ
6958	180	29,80	1-0-16-176-528 / 2



Afilador mango

Two stage knife sharpener
Affûteur couteau
Arrotino
Messerschärfer mit Griff

REF.	L(mm)	€	UE / MOQ
6957	190	10,73	1-0-36-180-360 / 6



Puente bambú piedra afiladora

Bamboo sharpening stone
Pierre à aiguiser en bambou
Pietra per affilare in bambù
Schärfstein aus bambus

* No incluye piedra de afilar
Sharpening stone not includes

REF.	L(mm)	W(mm)	H(mm)	€	MOQ
11029	430	100	90	58,32	1-0-0-0-0 / 1



Piedra de afilar 1000

Sharpening stone 1000
Pierre a aiguiser 1000
Pietra per affilare 1000
Schärfstein 1000

REF.	L(mm)	W(mm)	H(mm)	€	MOQ
11031	210	70	25	164,75	1-0-0-0-0 / 1



Piedra de afilar 400

Sharpening stone 400
Pierre a aiguiser 400
Pietra per affilare 400
Schärfstein 400

REF.	L(mm)	W(mm)	H(mm)	€	MOQ
11030	210	70	25	132,36	1-0-0-0-0 / 1



Piedra de afilar 5000

Sharpening stone 5000
Pierre a aiguiser 5000
Pietra per affilare 5000
Schärfstein 5000

REF.	L(mm)	W(mm)	H(mm)	€	MOQ
11033	210	70	25	263,79	1-0-0-0-0 / 1



Piedra de afilar 3000

Sharpening stone 3000
Pierre a aiguiser 3000
Pietra per affilare 3000
Schärfstein 3000

REF.	L(mm)	W(mm)	H(mm)	€	MOQ
11032	210	70	25	139,50	1-0-0-0-0 / 1



Asentador

Strop
Strop
Strop
Strop

REF.	L(mm)	W(mm)	H(mm)	€	MOQ
11037	350	80	45	98,57	1-0-0-0-0 / 1



Placa acero diamantada

Diamond steel plate
Plaque en acier diamant
Piastra in acciaio diamantato
Diamant-stahlplatte

REF.	L(mm)	W(mm)	H(mm)	€	MOQ
11034	203	76	10	155,71	1-0-0-0-0 / 1



Conoce UTSET en la página: 494
More about UTSET in page: 494

El maletín es la mejor opción para mantener tus cuchillos organizados y con el filo protegido para un afilado duradero.

La manera más segura de transportar tu selección de cuchillos donde necesites.

The Knife roll is the best option to keep your knives organised and edge protected for long-lasting sharpness

The safest way to transport your knife selection wherever you need it.

2 cierres de plástico de alta seguridad

2 high-security plastic closures

Tela adicional con cremallera para proteger los cuchillos

The long cuffs provide extra protection for your forearms.



Bolsillos con banda elástica para sujetar los cuchillos con seguridad.

Pockets with elastic band to hold knives securely.

Asa de mano + tira ajustable para colgar para un transporte más práctico.

Hand grip handle + adjustable hanging strap for convenient carrying.



Bolsa Porta Cuchillos
Knife roll
Sac porte-couteaux
Borsa portacoltelli
Tragebeutel für messer

REF.	L(mm)	W(mm)	H(mm)	€	UE / MOQ
11035	520	60	200	69,51	1-0-10-0-0 / 1



NEW

Funda Protectora Abs
Abs protective sheath
Étui de protection abs
Custodia protettiva In plastica
Schutzhülle abs

REF.	MEDIDAS / SIZES	€	UE / MOQ
11734	120 x 35 mm	4,24	1-30-240-0-0 / 1
11735	160 x 35 mm	4,38	1-30-240-0-0 / 1
11736	200 x 55 mm	4,98	1-30-240-0-0 / 1
11737	240 x 65 mm	5,63	1-30-240-0-0 / 1
11738	270 x 55 mm	5,58	1-30-240-0-0 / 1

Tejido de Nylon resistente que protege los cuchillos de golpes y evita pinchazos y cortes.

Durable nylon fabric protects knives from knocks and prevents punctures and cuts.



Incluye maletín con compartimentos específicos para utensilios de cocina.

Includes case with specific compartments for kitchen utensils.



NEW

Mochila chef con maletín portacuchillos
Chef backpack with knife holder case
Sac à dos de chef avec étui porte-couteaux
Zaino da chef con custodia portacoltelli
Kochrucksack mit Messerhalteretui

REF.	L(mm)	W(mm)	H(mm)	€	UE / MOQ
12022	320	140	460	150,65	1-0-6-0-0 / 1

NEW

Delantal cocina
Kitchen apron
Tablier de cuisine
Grembiule da cucina
Küchenschürze

REF.	L(mm)	€	UE / MOQ
12023	180	62,50	1-0-12-0-0 / 1





Acero inoxidable AISI 420-4034
Stainless steel

HRc 56 Rockwell

Microdentada
Micro-Toothed

Forjada en caliente
Hot forged

Diseño ergonómico
Ergonomic design

Todo tipo de alimentos
All types of food

INOX STAINLESS STEEL 420

Tijera profesional 8"
Scissors prof. Inox 8"
Ciseaux prof. Acier 8"
Forbice prof. Acciaio 8"
Stahl prof Schere 8"

REF.	L _(mm)	€	UE / MOQ
5164	200	83,65	1-0-6-84-588 / 1

FORJADO FORGED



INOX STAINLESS STEEL 420

Tijera master 8"
Scissors master inox 8"
Ciseaux master acier 8"
Forbice master acciaio 8"
Stahl Maister Schere 8"

REF.	L _(mm)	€	UE / MOQ
5165	200	64,65	1-0-6-84-588 / 1

FORJADO FORGED



INOX STAINLESS STEEL 420

Tijera cocina inox
Kitchen scissors
Ciseaux de cuisine
Forbici cucina
Küchenschere

REF.	L _(mm)	€	UE / MOQ
3910	220	27,65	1-12-48-288-576 / 12



Cascanueces
Nut cracker
Case-noix
Rompinoci
Nussknacker

REF.	L _(mm)	€	UE / MOQ
3623	160	11,32	1-10-50-900-2700 / 10



INOX STAINLESS STEEL 304

Tenedor marisco
Shellfish fork
Fourchette crustacé
Forchetta crostacei
Fischgabel

REF.	L _(mm)	€	UE / MOQ
5099	220	2,78	0-12-120-3000-15k / 12



INOX STAINLESS STEEL 2Cr14
PP POLYPROPYLENE

Tijera para aves
Poultry shears
Coupe volailles
Trinciapollo
Geflügelschere

REF.	L _(mm)	€	UE / MOQ
8989	200	17,86	1-6-36-216-432 / 6



INOX STAINLESS STEEL 3Cr13
NYLON

Tijera cocina 8,5
Kitchen scissors 8,5
Ciseaux cuisine 8,5
Forbice multiuso 8,5
Küchenschere 8,5

REF.	L _(mm)	€	UE / MOQ
8988	210	7,23	1-12-96-576-576 / 12



Pinza rompe marisco
Lobster cracker
Pince homard
Pinza per aragosta
Hummerkuacker

REF.	L _(mm)	€	UE / MOQ
0738	190	12,58	1-5-50-350-1400 / 12



NEW

Pinza marisco
Shellfish cracker
Pince à fruits de mer
Pinza per frutti di mare
Schalientier-pinzette

REF.	L _(mm)	€	UE / MOQ
11827	190	14,29	1-12-96 / 1



Regulador de grueso del corte.

Cutting thickness regulator.

Soporte para sujeción de verduras y frutas con protección para los dedos.

Vegetable and fruit holder with finger protection.

Pies plegables y antideslizantes.

Foldable, non-slip feet.



CUCHILLA / BLADE:
RODAJAS

CUCHILLA / BLADE:
JULIANA 4MM

CUCHILLA / BLADE:
JULIANA 6MM

CUCHILLA / BLADE:
JULIANA 10MM

CUCHILLA / BLADE:
GOFRADO



NEW

Mandolina Inox
Stainless Steel Mandoline
Mandoline Inox
Mandolina Inox
Edelstahl Mandoline

REF.	L(mm)	W(mm)	H(mm)	€	UE / MOQ
11748	395	123	42	81,63	1-0-6-0-0/1



Corte / Ralladores profesionales
Cutting / Professional graters



Rallador WIDE extra fino
St. Steel "wide" grater extra-thin
Râpe en inox coupe ultra fine
Grattugia taglio superfine
Breit rostfreie Reibe extra fein

REF.	L HOJA	L TOTAL	€	UE / MOQ
8946	135	320	7,52	1-6-96-576-576 / 6



Rallador WIDE grueso
St. Steel "wide" grater extra coarse
Râpe en inox coupe épaisse
Grattugia taglio spesso
Breit rostfreie Reibe grob

REF.	L HOJA	L TOTAL	€	UE / MOQ
8948	135	320	7,52	1-6-96-576-576 / 6



Rallador SLIM fino
St. Steel lengthways grater thin
Râpe longue en inox coupe fine
Grattugia lunga taglio fine
Schmal rostfreie Reibe fein

REF.	L HOJA	L TOTAL	€	UE / MOQ
8950	220	410	7,52	1-6-96-576-576 / 6



Rallador SLIM grueso
St. Steel lengthways grater extra coarse
Râpe longue en inox coupe épaisse
Grattugia lunga taglio spesso
Schmal rostfreie Reibe grob

REF.	L HOJA	L TOTAL	€	UE / MOQ
8952	220	410	7,52	1-6-96-576-576 / 6



Rallador WIDE fino
St. Steel "wide" grater thin
Râpe en inox coupe fine
Grattugia taglio fine
Breit rostfreie Reibe fein

REF.	L HOJA	L TOTAL	€	UE / MOQ
8947	135	320	7,52	1-6-96-0-576-576 / 6



Rallador WIDE tiras largas
St. Steel "wide" grater large shaver
Râpe en inox coupe julienne
Grattugia taglio julienne
Breit rostfreie Reibe mit lange

REF.	L HOJA	L TOTAL	€	UE / MOQ
8949	135	320	7,52	1-6-96-768-768 / 6



Rallador SLIM medio redondo
St. Steel lengthways grater medium
Râpe longue en inox coupe redondo moyen
Grattugia lunga taglio mezzo giro
Schmal rostfreie Reibe medium

REF.	L HOJA	L TOTAL	€	UE / MOQ
8951	220	410	7,52	1-6-96-576-576 / 6

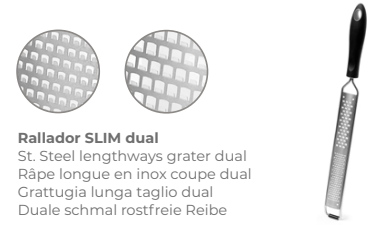

Rallador SLIM dual
St. Steel lengthways grater dual
Râpe longue en inox coupe dual
Grattugia lunga taglio dual
Duale schmal rostfreie Reibe

REF.	L HOJA	L TOTAL	€	UE / MOQ
8953	220	410	7,52	1-6-96-576-576 / 6

Se presenta con una funda de plástico para proteger la zona de corte

Comes with a plastic sheath to protect the cutting edge

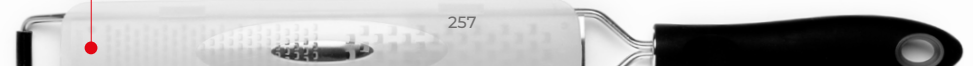

Mango ergonómico
Ergonomic handle

INOX
STAINLESS
STEEL
430

Acero inoxidable resistente al
desgaste y la corrosión.

Wear and corrosion resistant
stainless steel.



Grueso
Coarse



Fino
Fine



Medio
Medium



Rebanador
Slicer

Rallador 4 caras HQ
4 side grater HQ
Râpe 4 cotés HQ
Grattugia 4 facce HQ
Vierkantreibe HQ

REF.	H(mm)	€	UE / MOQ
7448	240	7,32	1-12-72-288-288 / 6



INOX
STAINLESS
STEEL
201

Rallador 4 caras
4 side grater
Râpe 4 faces
Grattugia 4 lam.
Vierkantreibe

REF.	H(mm)	€	UE / MOQ
1150	210	5,52	1-0-60-720-2160 / 6



NEW

Abrelatas Inox
Stainless Steel Tin Opener
Ouvre-Boîte Inox
Apriscatole In Acciaio Inox
Dosenöffner Edelstahl

REF.	L(mm)	W(mm)	H(mm)	€	UE / MOQ
11818	65	45	28	2,88	1-0-96-0-0 / 1

INOX
STAINLESS
STEEL
430

Pelapatatas
Potato-peeler
Économe acier inox
Pelapatate
Kartoffelschäler



REF.	L(mm)	€	UE / MOQ
3455	110	2,02	1-12-12-36-72 / 12



Rasqueta plancha profesional 30cm
Professional scraper
Racleur professionnelle
Raschietti
Schaber glatt

REF.	L(mm)	€	UE / MOQ
8474	300	10,69	1-12-24-288-2016 / 12

Recambio 10 cuchillas
Blister 10 blades
Blister 10 lames
Blister 10 lame
Blister 10 messer



REF.	€	UE / MOQ
8507	4,09	1-50-100-1100-6600 / 10

Rodillo de recambio
Wheel (spare part)
Rouleau (pièce de rechange)
Rullo
Austauschrad

REF.	€	UE / MOQ
8566	20,96	1-0-200-3000-9000 / 1

Cuchilla de recambio
Knife (spare part)
Couteau (pièce de rechange)
Lame
Austauschklinge

REF.	€	UE / MOQ
8565	7,86	1-0-200-3000-9000 / 1



NEW

Cepillo
Scraper
Brosse À Gratter
Raschietto
Schaber

REF.	L(mm)	W(mm)	H(mm)	€	UE / MOQ
11946	470	125	55	51,38	1-0-6-0-0 / 1

Recambio Cepillo
Replacement Scraper Brush
Pièce De Recharge Brosse À Gratter
Ricambio Spazzola Raschietto
Ersatzbürste Schaber

REF.	L(mm)	W(mm)	H(mm)	€	UE / MOQ
11947	125	70	17	11,88	1-0-24-0-0 / 1



Abrelatas industrial
Can opener
Ouvre-boîtes professionnel
Apriscatole
Industrieller edelstahl dosenöffner

REF.	H(mm)	€	UE / MOQ
8564	600	154,60	1-0-8-16-16 / 1



Espátula pastelera
Baker spatula
Palette
Spatola cuoco
Kuchenspachtel



REF.	SIZE	HOJA (mm)	€	UE / MOQ
8932	S	135	2,21	1-12-48-576-1152 / 12
8933	M	225	2,50	1-12-48-480-960 / 12
8934	L	300	3,13	1-12-48-432-864 / 12



Pala repostería
Cake server
Pelle à gâteau
Spatola dolci
Kekss-Spachtel



REF.	W (mm)	€	UE / MOQ
8941	120	2,74	1-12-48-384-1152 / 12



Espátula flexible acodada
Angular spatula
Palette coudée
Spatola cuoco con scalino
Winkelpalette



REF.	SIZE	HOJA (mm)	€	UE / MOQ
8938	S	140	2,74	1-12-48-384-768 / 12
8937	L	200	2,90	1-12-48-288-864 / 12

Mango de polipropileno (PP) de forma redondeada para una sujeción más cómoda.

Rounded polypropylene (PP) handle for a more comfortable grip.

Piezas aptas para lavavajillas.

Dishwasher safe.

Alta resistencia a la corrosión.

Highly rust-resistant.

Pala fabricada en Acero inoxidable endurecido de alta calidad.

Spatula in high-quality hardened stainless steel.

Acabado satinado.

Satin finished.

Resistencia y flexibilidad para facilitar el trabajo en la cocina.

Hard-wearing and versatile round the kitchen.



Espátula plancha rectangular biselada
Solid, beveled turner
Palette pleine, biseauté
Spatola hamburger
Bratenspachtel Rechtechteige



REF.	W (mm)	H (mm)	€	UE / MOQ
8935	80	120	3,71	1-12-48-384-768 / 12



Paleta plancha triangular
Cleaning spatula
Palette triangle
Spatola triangolare
Dreieckige Bratenspachtel



REF.	SIZE	HOJA (mm)	€	UE / MOQ
8939	S	80	2,94	1-12-48-576-1152 / 12
8940	L	100	3,03	1-12-48-480-960 / 12



Espátula pescado
Fish spatula
Spatule poisson
Pesce spatola
Fischspachtel

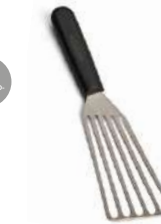

REF.	W (mm)	L (mm)	€	UE / MOQ
9996	80	290	2,90	1-12-48-384-768 / 1



Espátula plancha rectangular biselada mango madera
Spatula. Wood handle
Palette. Manche en bois
Spatola hamburger
Bratenwender mit Holzgriff



REF.	MODELO	W (mm)	L (mm)	€	UE / MOQ
8942	RECTANGULAR	80	290	4,43	1-12-48-384-768 / 12
8943	TRIANGULAR	80	235	3,66	1-12-48-384-1920 / 12



Espátula pescado biselada
Fish turner
Palette poisson
Spatola pesce
Fischschaufel



REF.	W (mm)	H (mm)	€	UE / MOQ
8936	75	165	4,34	1-12-48-384-768 / 12



Espátula angular emplataado
Angular spatula
Mini spatule
Spatola
Kleine Winhelpalette



REF.	L Total (mm)	Paleta (mm)	€	UE / MOQ
8476	220	95	4,51	1-48-288-1728-5184 / 12



Mini lengua de silicona
Silicone spoon
Cuillère silicone
Spatola silicone
Silikonlöffel



REF.	L (mm)	COLOR	€	UE / MOQ
5161	170	ROJA	3,97	1-24-96-1920-5760 / 24





INOX STAINLESS STEEL 430



Molde redondo
Round ring
Moulage rond
Teglia tondo
Runcle Kochringe

REF.	Ø(mm)	H(mm)	€	UE / MOQ
7461	60	45	1,45	1-32-128-512-1536 / 12
7462	70	45	1,45	1-32-128-768-1536 / 12
7463	80	45	1,72	1-32-128-768-1536 / 12
7464	90	45	1,85	1-32-128-768-1536 / 12
7465	100	45	1,98	1-32-128-256-512 / 12
7466	120	45	2,11	1-32-128-256-512 / 12

REF.	SET	€	UE / MOQ
7449	PACK 6	11,13	1-24-48-192-392 / 6

INOX STAINLESS STEEL 430



Molde cuadrado
Square ring
Moulage carre
Teglia quadrato
Quadratische Kochringe

REF.	W/L (mm)	H(mm)	€	UE / MOQ
7467	60x60	45	1,67	1-32-128-512-1536 / 12
7468	70x70	45	1,85	1-32-128-768-1536 / 12
7469	80x80	45	2,11	1-32-128-768-1536 / 12
7470	90x90	45	2,38	1-32-128-768-1536 / 12
7471	100x100	45	2,64	1-32-128-768-1536 / 12
7472	120x120	45	2,51	1-32-128-768-1536 / 12

REF.	SET	€	UE / MOQ
7450	PACK 6	13,48	1-24-48-192-392 / 6



Punta estriada para un mejor agarre de los alimentos

Grooved tip for a better grip of the foods.



Pinza chef recta
Straight chef tong
Pince chef droite
Pinze chef diritta
Pinzettenzange

INOX STAINLESS STEEL 430

REF.	L(mm)	€	UE / MOQ
7477	210	6,64	1-24-96-1920-5760 / 6
7478	300	9,67	1-24-96-1920-5760 / 6

INOX STAINLESS STEEL 430



Pinza chef curva
Curved chef tong
Pince chef courbée
Pinze chef curve
Gebogene Pinzette

REF.	L(mm)	COLOR	€	UE / MOQ
7473	145	INOX	5,61	1-24-96-1920-5760 / 6
7474	200	INOX	7,08	1-24-96-1920-5760 / 6
8680	200	ORO	7,40	1-24-96-1920-5760 / 6
8681	200	COBRE	7,40	1-24-96-1920-5760 / 6
8682	200	NEGRO	7,40	1-24-96-1920-5760 / 6

INOX STAINLESS STEEL 430



Pinza chef quitaespinas
Fish bone chef tong
Pince chef à désarêter
Pinze lisca del pesce chef
Frischgräten küchenmeister zange

REF.	L(mm)	€	UE / MOQ
7479	120	3,59	1-24-96-1920-5760 / 6



Pinza chef precisión
Precision chef tong
Pince chef précision
Pinze chef precisione
Präzisions-Kochpinzette

INOX STAINLESS STEEL 430

REF.	L(mm)	€	UE / MOQ
7475	160	5,90	1-24-96-1920-5760 / 6
7476	240	7,72	1-24-96-1920-5760 / 6

OPCIÓN DE PERSONALIZACIÓN CON LASER.
LASER PERSONALISATION OPTION



8682



8681



8680



NEW

INOX STAINLESS STEEL 430



Pinza quitaespinas
Fish bone tong
Pince à désarêter
Pinze lisca del pesce
Frischgräten pinzette

REF.	L(mm)	W(mm)	H(mm)	€	UE / MOQ
11819	135	19	20	3,17	1-0-72 / 1

Cocina / Kitchen

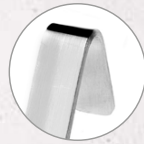

Mango con gancho para un fácil almacenamiento.

Hook handle for easy storage



Capacidad grabada en el mango.

Capacity engraved on the handle

Acabado brillo. Menos poroso, facilita la limpieza.

Mirror finish. Less porous, easier to clean.

Mango más grueso con nervio central que le proporciona más rigidez y resistencia.

Thicker handle with a central rib for more rigidity and stiffens and strengthens the handle.



Monoblock / Monoblock

INOX
STAINLESS
STEEL
201

Espumadera con malla
Mesh skimmer
Écumoire maillée
Schiumarola a rete passabrodo
Draht Schaumlöffel

REF.	Ø _(mm)	€	UE / MOQ
9735	140	13,73	1-0-50-120-450 / 10
9736	160	15,40	1-0-30-120-360 / 10
9737	180	17,45	1-0-30-120-360 / 10
9738	200	19,25	1-0-30-90-270 / 10
9739	240	21,68	1-0-30-90-270 / 10

INOX
STAINLESS
STEEL
430

Cazo Monoblock
One piece ladle
Louche monoblock
Mestolo monoblock
Schöpfhelle monoblock

REF.	Ø _(mm)	L _(mm)	ml	€	UE / MOQ
9712	65	300	70	9,03	1-10-240-720 / 10
9713	80	320	125	10,47	1-6-60-240-480 / 10
9714	90	330	200	11,70	1-10-40-160-480 / 10
9715	100	370	250	13,86	1-10-40-160-320 / 10
9716	120	430	430	15,65	1-10-40-160-320 / 10
9717	140	440	650	19,29	1-10-40-160-320 / 10
9718	160	470	950	22,50	1-10-20-40-160 / 10

INOX
STAINLESS
STEEL
201

Cuchara servir monoblock
One piece spoon
Couliere monoblock
Cucchiaio monoblock
Servierlöffel

REF.	L _(mm)	€	UE / MOQ
9726	330	10,27	1-10-60-120-480 / 10

INOX
STAINLESS
STEEL
201

Tenedor 2 púas monoblock
One piece meat fork
Fourchette monoblock
Forchetta monoblock
Fleischgabel monoblock

REF.	L _(mm)	€	UE / MOQ
9728	520	13,47	1-20-60-300-1500 / 10

Utensilios / Juegos de cocina Utensils / Kitchen tool

INOX
STAINLESS
STEEL
201

Araña
Tinned skimmer
Écumoire étamée
Schiumarola filo
Fritierlöffel

REF.	Ø _(mm)	€	UE / MOQ
9729	140	9,60	1-0-50-200-400 / 10
9730	160	10,00	1-0-25-100-200 / 10
9731	180	10,75	1-0-25-100-200 / 10
9732	200	11,39	1-0-25-100-200 / 10
9733	220	12,49	1-0-25-100-200 / 10
9734	240	13,58	1-0-25-100-200 / 10

INOX
STAINLESS
STEEL
201

Espumadera Monoblock
One piece skimmer
Écumoire monoblock
Schiumarola monoblock
Schäumerlöffel

REF.	Ø _(mm)	L _(mm)	€	UE / MOQ
9719	80	290	6,93	1-10-60-240-480 / 10
9720	100	320	8,98	1-10-60-240-720 / 10
9721	120	350	11,76	1-10-40-160-480 / 10
9722	140	380	13,35	1-10-40-160-480 / 10
9723	160	410	15,91	1-10-40-160-320 / 10
9724	180	430	20,53	1-10-40-80-240 / 10
9725	200	450	24,38	1-10-40-80-240 / 10

INOX
STAINLESS
STEEL
201

Espátula perforada
Perforated spatula
Spatule perforée
Spatola forata
Pfanneschaufel perforiert

REF.	L _(mm)	€	UE / MOQ
9727	350	11,81	1-12-48-420-840 / 10



Nylon
Fibra de alta calidad.
Poca porosidad mayor du-
reza.

Nylon
High-quality fibres.
Non-porous, more hard-wea-
ring.

BPA FREE
BPA FREE

Alta resistencia térmica.
Soportan temperatura de
hasta 220°C

Strong heat-resistance.
For use in temperatures
up to 220 °C

No raya.
Suavidad con las superfi-
cies antiadherentes

Non-scratching.
Delicate on
non-stick surfaces

Gancho que permite colgar
para un práctico almacenaje.

Hanging for convenient stor-
rage.



Muesca
antivuelco
No tipping

			L mm	Ø mm	ml	€	UE / MOQ
A	11809	CUCHARA NYLON Spoon, Cuillère, Cucchiaio, Löffel	49			14,69	1-0-75 / 1
B	11810	CUCHARÓN NYLON 10 Spoon, Louche, Mestolo, Schöpflöffel	48	Ø 100	200ml	14,97	1-0-50 / 1
	11811	CUCHARÓN NYLON 12 Spoon, Louche Mestolo, Schöpflöffel	50	Ø 120	350ml	16,85	1-0-75 / 1
	11812	CUCHARÓN NYLON 14 Spoon, Louche, Mestolo, Schöpflöffel	51	Ø 140	500ml	17,91	1-0-50 / 1
C	11813	ESPÁTULA NYLON PERFORADA Slotted, Spatula, Spatule Perforé, Spatola Forata, Scharfelf perforiert	51			16,85	1-0-75 / 1
D	11814	ESPÁTULA NYLON SIN AGUJEROS Spatula W/O, Spatulle Sans Trou, Spatola Senza Buchi, Pfannenwender Ohne Löcher	51			16,85	1-0-75 / 1
E	11815	ESPUMADERA NYLON 10 Skimmer, Ecumoire, Schiumarola, Schaumlöffel	44	Ø 100		14,97	1-0-75 / 1
	11816	ESPUMADERA NYLON 12 Skimmer, Ecumoire, Schiumarola, Schaumlöffel	45	Ø 120		16,85	1-0-75 / 1
	11817	ESPUMADERA NYLON 14 Skimmer, Ecumoire, Schiumarola, Schaumlöffel	47	Ø 140		17,91	1-0-75 / 1

			L mm	€	UE / MOQ
A	8405	CUCHARA SPAGUETTI Spaguetti server, Cuillère spaguetti, Servispaguetti, Spaguettilöffel	325	4,70	1-0-12-120-480 / 12
B	8407	PINZA COCINA Kitchen pincers, pince, pinza cucina, zange	310	4,51	1-0-12-120-480 / 12
C	8398	CAZO Ladle, louche, mestolo, schöflöffel	330	5,46	1-0-24-120-480 / 12
D	8400	ESPÁTULA PERFORADA Slotted Spatula, Spatule Perforé, Spatola Forata, Pfannenwender Mit Schlitzen	345	4,08	1-0-12-120-480 / 12
E	8399	ESPUMADERA Skimmer Ecumoire Schiumarola Schaumlöffel	335	4,61	1-0-12-120-480 / 12
F	8402	PALA LASAÑA Lasagna shovel, palette à lasagne, pala lasagna, lasagneheber	290	4,32	1-0-12-120-480 / 12
G	8404	PALA FREIR Lasagna shovel, palette à lasagne, pala lasagna, lasagneheber	290	4,57	1-0-12-120-480 / 12
H	8403	CUCHARA SERVIR Rice shovel, cuillère de service, cucchialone riso, servierlöffel	285	4,13	1-0-12-120-480 / 12
I	8406	ESPÁTULA CREPES creppes spatula, palette, spatola creppes, kuchenheber	335	4,10	1-0-12-120-480 / 12
J	8401	PALETA PESCADO Universal shovel, pelle à poisson, pala multuso, fischheber	335	4,11	1-0-12-120-480 / 12



Espátula madera
Solid turner
Spatule en bois
Spátola di legno
Holzspachtel



REF.	L _(mm)	€	UE / MOQ
10717	330	4,10	1-12-72 / 12



Cuchara madera
Ponited spoon
Cuillère en bois
Cucchiaio di legno
Holzlöffel



REF.	L _(mm)	€	UE / MOQ
10718	330	4,10	1-12-72 / 12



Barra de comandas
Order rack
Porte-fiches à billes
Asta portascontrini
Zettelfeiste



REF.	W _(mm)	L _(mm)	H _(mm)	€	UE / MOQ
9760	24	615	24	12,71	1-6-24-168-672 / 6
11776	58	1000	22	20,96	1-0-24 / 1



Espolvoreador 3 posiciones
Stainless steel sprinkler 3p
Saupoudreuse acier 3p
Draga acciaio 3p
Strendose 3 pos.



REF.	H _(mm)	€	UE / MOQ
8794	110	5,29	1-1-100-600-1200 / 1



Escure fritos y carnes
Fry colander
Passoire à frites
Cesta per frigere
Frittensieb



REF.	W _(mm)	L _(mm)	€	UE / MOQ
8381	290	400	153,34	1-0-6-24-24 / 1
8382	390	500	189,04	1-0-4-12-24 / 1
8383	390	600	215,22	1-0-3-9-27 / 1



Biberón rojo
Red squeeze bottles
Distributeur
à pression rouge
Garrafa rosso
Dosierflasche rot



REF.	ml	H _(mm)	€	UE / MOQ
8439	240	190	1,57	1-4-24-240-720 / 24
8440	360	220	1,78	1-4-24-192-960 / 24
8441	720	260	2,11	1-4-24-144-576 / 24

Biberón amarillo
Yellow squeeze bottles
Distributeur
à pression jaune
Garrafa giallo
Dosierflasche Gelb



REF.	ml	H _(mm)	€	UE / MOQ
8442	240	190	1,57	1-4-24-240-720 / 24
8443	360	220	1,78	1-4-24-192-960 / 24
8444	720	260	2,11	1-4-24-144-720 / 24



Triple boquilla:
ideal para decoraciones.
Triple nozzle:
great for decorations.

Biberón triple
Triple squeeze bottle
Triple distributeur
Garrafa com boquilha triplo
Dosierflasche mit Dreifachdüse

REF.	ml	H _(mm)	€	UE / MOQ
8449	360	180	2,09	1-4-24-192-960 / 24
8450	720	245	2,50	1-4-24-144-576 / 24



Todos los biberones
tienen marcas de medición
en milímetros.
All bottles
have measurement marks
in millimeters.

Biberón transparente
Clear squeeze bottles
Distributeur à pression transparent
Garrafa trasparente
Dosierflasche transparent

REF.	ml	H _(mm)	€	UE / MOQ
8445	240	190	1,57	1-4-24-240-1200 / 24
8446	360	220	1,78	1-4-24-216-1080 / 24
8447	720	260	2,10	1-4-24-144-576 / 24
8448	1.000	310	3,63	1-4-24-96-384 / 24



INOX
STAINLESS
STEEL
201

Rustidera
Lasagna pan
Plat à rôtir
Rostiera
Lasagneform



REF.	W (mm)	L (mm)	H (mm)	€	UE / MOQ
1422	250	180	40	10,00	1-0-24-144-288 / 4
1421	300	220	50	13,58	1-0-12-72-144 / 4
1420	350	260	50	18,07	1-0-12-72-144 / 4
1419	400	300	60	21,96	1-0-12-72-144 / 4
5282	450	320	65	50,36	1-0-4-16-48 / 4
5283	500	360	70	61,86	1-0-4-16-32 / 4
5284	600	400	75	79,19	1-0-4-16-16 / 4

INOX
STAINLESS
STEEL
201

Pinza para rustidera
Lasagna pan tong
Pince plat à rôtir
Molla forno
Ofenzange



REF.	L (mm)	€	UE / MOQ
5656	185	7,35	1-10-100-600-1800 / 6

INOX
STAINLESS
STEEL
304

Harinero
Flour bin
Tamis à farine inox
Farinheiro
Mehlsieb

REF.	W (mm)	L (mm)	H (mm)	€	UE / MOQ
8384	265	370	180	129,52	1-0-1-8-24 / 1
8385	265	500	180	147,65	1-0-1-6-18 / 1
8386	330	500	180	150,72	1-0-1-4-12 / 1

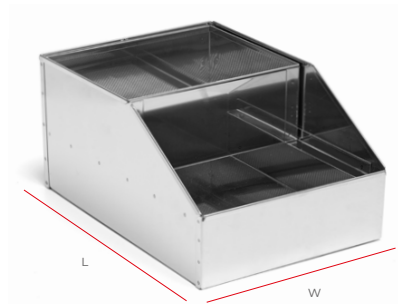

NEW

INOX
STAINLESS
STEEL
201

Colador Chino Piston
Piston Funnel
Passoire Chinois Piston
Colino Chinese A Pistone
Passiersieb



REF.	L (mm)	W (mm)	H (mm)	€	UE / MOQ
11777	280	200	240	59,68	1-0-8-0-0 / 1

INOX
STAINLESS
STEEL
201

Colador chino con clip
Conical soup strainer with clip
Passoire chinois
Cornetto cinese
Spitzsieb



REF.	Ø (mm)	€	UE / MOQ
9764	160	5,83	1-0-60-240-480 / 10
9765	180	6,95	1-0-60-240-480 / 10
9766	200	8,50	1-0-60-240-480 / 10
9767	220	9,68	1-0-60-240-480 / 10
9768	240	10,69	1-0-30-120-240 / 10
9769	260	11,87	1-0-30-120-240 / 10

NEW

INOX
STAINLESS
STEEL
201

Colador Malla
Mesh Sieve
Passoire Maille
Colino A Maglia
Küchensieb



REF.	Ø (mm)	H (mm)	€	UE / MOQ
11950	200	220	18,94	1-0-6-0-0 / 1
11949	250	270	24,00	1-0-6-0-0 / 1

INOX
STAINLESS
STEEL
201

Colador fino
Oil strainer
Passoire à huile
Colino per l'olio
Ölsieb

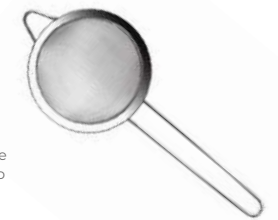

REF.	Ø (mm)	€	UE / MOQ
2884	80	2,61	1-0-24-960-1920 / 6
2885	100	2,92	1-0-24-960-1920 / 6
2886	120	3,94	1-0-24-960-1920 / 6
2887	140	4,42	1-0-24-960-1920 / 6
2888	160	4,59	1-0-24-960-1920 / 6
2889	180	5,70	1-0-24-960-1920 / 6
2890	200	6,32	1-0-24-960-1920 / 6

INOX
STAINLESS
STEEL
304

Cedazo Velo
Sieve velo
Tamis velo
Setaccio velo
Mehlsieb

REF.	Ø (mm)	€	UE / MOQ
10650	250	13,53	1-6-12-96-192 / 1
10651	300	16,95	1-6-12-36-108 / 1
10652	350	21,39	1-4-8-48-96 / 1



MEDIDA MALLA / MESH SIZE:
1,5 x 1 mm

INOX
STAINLESS
STEEL
304

Cedazo Harina
Flour sieve
Tamis farine
Setacciofarina
Mehlsieb

REF.	Ø (mm)	€	UE / MOQ
10653	250	13,53	1-6-12-96-192 / 1
10654	300	16,95	1-6-12-72-144 / 1
10655	350	21,39	1-4-8-48-96 / 1



MEDIDA MALLA / MESH SIZE:
2,5 x 1,4 mm

INOX
STAINLESS
STEEL
304

Cedazo Pan
Bread Sieve
Tamis pain
Setaccio pane
Brotsieb

REF.	Ø (mm)	€	UE / MOQ
10656	300	16,95	1-6-12-36-108 / 1
10657	350	21,39	1-4-8-48-96 / 1



MEDIDA MALLA / MESH SIZE:
4 x 3 mm

INOX
STAINLESS
STEEL
304

Cedazo Pescado
Fish sieve
Tamis poisson
Setaccio peixe
Fischsieb

REF.	Ø (mm)	€	UE / MOQ
10658	300	16,95	1-6-12-36-108 / 1
10659	350	21,39	1-4-8-48-96 / 1



MEDIDA MALLA / MESH SIZE:
11 x 9 mm

Cocina / Kitchen

INOX
STAINLESS
STEEL
430

Barillas de acero inoxidable de alta resistencia.

Tough stainless steel bars.

NYLON

Mango de nylon de forma ergonómica. Con relieves para mejorar el agarre.

Ergonomic nylon handle. Raised pattern for better grip.

Fácil almacenaje.
Easy to store.



Batidor 8 varillas Nylon

REF.	L (mm)	VARILLAS (mm)	€	UE / MOQ
8480	250	12	8,11	1-12-48-380-1920 / 12
8481	300	170	9,25	1-12-48-288-864 / 12
8482	350	220	10,96	1-12-48-284-864 / 12
8483	400	250	11,67	1-6-24-120-600 / 6



INOX
STAINLESS
STEEL
201

Batidor 8 varillas

REF.	L (mm)	VARILLAS (mm)	€	UE / MOQ
9740	250	12	8,57	1-0-30-360-720 / 10
9741	300	170	8,67	1-0-30-270-540 / 10
9742	350	220	9,09	1-0-30-240-480 / 10
9743	400	250	9,99	1-0-30-180-360 / 10
9744	450	290	10,45	1-0-30-120-240 / 10
9745	500	370	10,91	1-0-30-120-240 / 10



Cuchara silicona
Silicon spoon
Cuillère silicone
Cucchiaio silicone
Silikonlöffel



REF.	L (mm)	€	UE / MOQ
8484	250	4,29	1-12-7-108-6048 / 12
8485	350	5,24	1-12-72-648-2592 / 12
8486	400	5,97	1-12-72-576-2304 / 12



Espátula silicona
Silicon spatula
Spatule silicone
Spatola silicone
Silikonspachtel



REF.	L (mm)	€	UE / MOQ
8487	250	4,29	1-12-72-1296-7776 / 12
8488	350	5,24	1-12-72-792-3168 / 12
8489	400	5,97	1-12-72-720-2880 / 12

Utensilios / Pastelería Utensils / Pastry

PP
POLYPROPYLENE

Jarra medidora
Measuring PP jug
Pichet gradué PP
Caraffa graduata
Messbecher



REF.	ml	H(mm)	€	UE / MOQ
8451	500	133	2,23	1-12-72-360-1080 / 12
8452	1.000	160	2,72	1-6-60-180-540 / 6
8453	2.000	215	3,90	1-6-60-180-180 / 6

INOX
STAINLESS
STEEL
201

Bol semiesférico
Mixing bowl
Bassine hémisphérique
Bastardella semisferica
Schnees Schlagkessel



REF.	Ø(mm)	€	UE / MOQ
9748	160	2,19	1-0-100-1000-3000 / 10
9749	220	4,06	1-0-50-600-1200 / 10
9750	240	4,87	1-0-50-600-1800 / 10
9751	300	8,14	1-0-50-300-600 / 10
9752	340	10,32	1-0-25-150-450 / 5
9753	360	11,05	1-0-25-150-450 / 5
9754	400	15,13	1-0-25-150-300 / 5

PASTELERÍA
PASTRY

PP
POLYPROPYLENE

Espátula pastelería
Small baker spatula
Spatule silicone
Palette
Spatola cuoco
Kuchenspachtel

REF.	SIZE	HOJA (mm)	€	UE / MOQ
8932	S	135	2,21	1-12-48-576-152 / 12
8933	M	225	2,50	1-12-48-480-960 / 12
8934	L	300	3,13	1-12-48-432-864 / 12

INOX
STAINLESS
STEEL
201

Flanar profesional
Pudding mould
Moule à flan
Crème caramel
Becherförmchen



REF.	Ø(mm)	H(mm)	€	UE / MOQ
9632	75	50	2,64	1-12-120-960-3840 / 12
9633	85	55	3,97	1-12-120-960-3840 / 12



Cocción / Sartenes y baterías profesionales
 Cooking / Professionals fry pans and cookware

COLECCIÓN SARTENES / FRY PANS COLLECTION

/ ETNA / TEIDE / VULCANO / CROSCAT / AUVERNIA / USSON / VESUVIO / FUJI



	SARTÉN FRY PAN	ALUMINIO ALUMINIUM	ALUMINIO ALUMINIUM	ALUMINIO ALUMINIUM	ALUMINIO ALUMINIUM	ALUMINIO ALUMINIUM	ALUMINIO ALUMINIUM	INOX	INOX
	MANGO HANDLE	INOX	INOX	INOX	INOX	HIERRO IRON	HIERRO IRON	INOX	INOX
	ANTIADHERENTE NON-STICK								
	VITRO	●	●	●	●	●	●	●	●
	ELÉCTRICO ELECTRIC	●	●	●	●	●	●	●	●
	GAS	●	●	●	●	●	●	●	●
	INDUCCIÓN INDUCTION		●		●		●	●	●
	HORNO OVEN	●	●	●	●				
	APTO CONTACTO ALIMENTARIO FOODCONTACT SAFE								

COLECCIÓN BATERIA / COOKWARE COLLECTION

CROSCAT



CUERPO BODY	ASAS HANDLES	ANTIADHERENTE NON-STICK	VITRO	ELÉCTRICO ELECTRIC	GAS	INDUCCIÓN INDUCTION	HORNO OVEN	APTO CONTACTO ALIMENTARIO FOODCONTACT SAFE



Doble capa antiadherente de alta calidad.

High quality double non-stick coating.

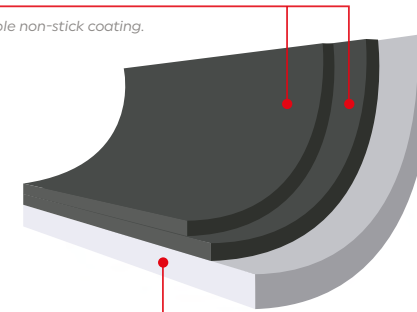

Aluminio de 3mm de espesor

3mm thick aluminium



Recomendamos el uso de utensilios de nylon para alargar la vida del recubrimiento antiadherente en perfectas condiciones.

We recommend the use of nylon utensils to extend the life of the non-stick coating in perfect condition.

Revestimiento antiadherente de fluororesina de grado universal de PFLUON con sistemas de revestimiento de dos capas. Esta serie de revestimientos es densa, antiadherente y fácil de limpiar.

PFLUON universal grade fluororesin non-stick coating with two-layer coating systems. This coating series is dense, non-stick and easy to clean.

PFLUON trabaja con el instituto de certificación de renombre mundial SGS para garantizar que los productos y servicios cumplen las normas mundiales y la normativa local. Podemos demostrarle que el antiadherente COOKMARK cumple las normas y especificaciones nacionales e internacionales.

PFLUON works with the world-renowned certification institute SGS to ensure that products and services meet global standards and local regulations. We can prove that COOKMARK non-stick coating meets national and international standards and specifications.



PACKAGING BOX

Sartenes diseñadas para resistir los servicios más exigentes.

Mango hermético.

Sealed handle.

Mango fabricado en acero inoxidable de forma tubular para facilitar la sujeción de la sartén.

Tubular stainless steel handle for easy handling.

Remachado al cuerpo de la sartén para proporcionar una sujeción superior y una máxima seguridad en el momento de su uso.

Riveted to the pan for strength and safety in use.

Eficiencia de la distribución calórica: Su cuerpo de aluminio de alta calidad capta y distribuye de la mejor manera el calor por toda la superficie.

Efficient conduction of heat: The high-quality aluminium body captures and conducts heat across the whole surface.



Recubrimiento totalmente libre de PFOA.

Coating totally PFOA-free.



4mm de grosor en tamaños grandes.
4mm thickness in large sizes.



ETNA

Sartén aluminio mango inox
Aluminium fry pan with inox handle
Poêle aluminium manche en inox
Padella in alluminio manico in inox
Bratpfanne aluminium mit inoxgriff

REF.	Ø(mm)	e(mm)	€	UE / MOQ
8342	180	2,5	14,73	1-0-6-54-324 / 12
8343	200	3,5	17,06	1-0-6-36-324 / 12
8344	220	3,5	20,42	1-0-6-30-240 / 12
8345	240	3,5	22,85	1-0-6-24-216 / 6
8346	260	4	26,17	1-0-6-24-216 / 6
8347	280	4	28,50	1-0-6-24-192 / 6
8348	320	4	35,38	1-0-6-12-96 / 6
8349	360	4	42,19	1-0-6-12-84 / 6
8350	400	4	50,93	1-0-6-12-96 / 6



TEIDE

Sartén aluminio mango inox / Inducción
Aluminium induction fry pan with inox handle
Poêle induction aluminium manche en inox
Padella induzione in alluminio manico en inox
Bratpfanne aluminium mit inoxgriff induktion



Fondo de inducción. Difusión rápida y uniforme del calor.
Induction base. Rapid, uniform distribution of heat.

REF.	Ø(mm)	e(mm)	€	UE / MOQ
8954	200	3	16,65	1-0-6-36-324 / 6
8955	240	3	21,00	1-0-6-24-216 / 6
8956	280	3	25,86	1-0-6-24-192 / 6
8957	320	3	30,97	1-0-6-12-96 / 6
11778	360	3	39,57	1-0-6-12-84 / 6
11996	400	3	53,40	1-0-6-12-96 / 6



VULCANO

Sartén aluminio antiadherente alta mango inox
Deep frypan, non stick coating
Poêle avec revêtement anti-adhésif
Padella inox antiaderente
Bratpfanne Aluminium mit inoxgriff



SARTÉN HONDA
DEEP PAN

REF.	Ø(mm)	e(mm)	H(mm)	€	UE / MOQ
9971	200	3	55	16,89	1-0-6-36-288 / 6
9972	240	3	60	21,45	1-0-6-24-192 / 6
9973	280	3	65	27,94	1-0-6-24-144 / 6
9974	320	3	75	33,06	1-0-6-0-0 / 6
9975	360	3	80	42,74	1-0-6-0-0 / 6
9976	400	3	85	49,89	1-0-6-0-0 / 6

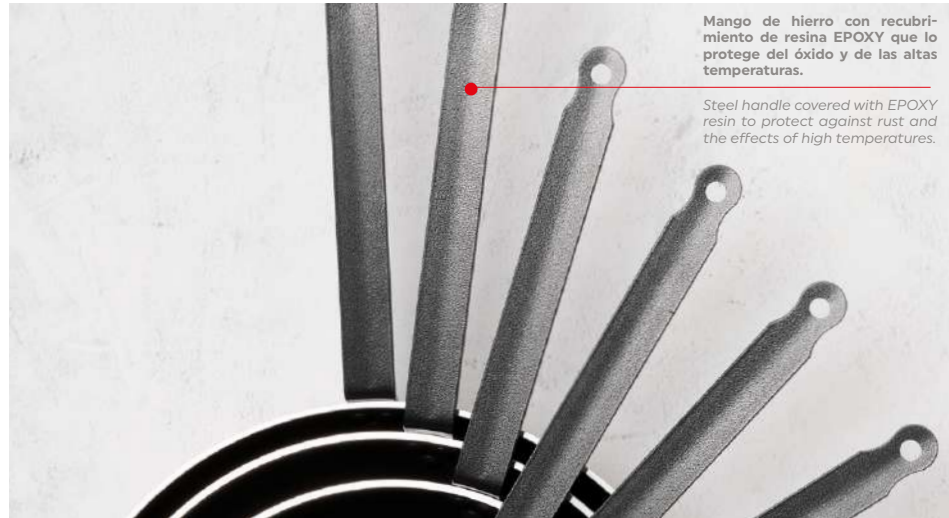

CAPAS EXTERIORES
ACERO INOXIDABLE
SUPERIOR
Mezcla cromo, titanio y cobre.

EXTERIOR LAYERS
SUPERIOR STAINLESS
STEEL
Mixing chrome, titanium and copper.

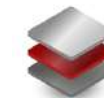

CAPA INTERIOR
ALUMINIO
INTERIOR LAYER
ALUMINIUM

BASE SANDWICH SYSTEM



- Alta resistencia a la corrosión y los ácidos alimentarios.
Highly resistant to rust and food acids.
- Menos porosidad, más higiénico.
Less porous, more hygienic surface.
- Óptima difusión del calor por toda la superficie.
Optimum heat distribution across the whole base.
- Muy resistente a las altas temperaturas y al desgaste.
Hard-wearing and tolerant of high temperatures.
- Apta para inducción.
Suitable for induction.



AUVERNIA

Sartén aluminio mango hierro
Aluminium fry pan with iron handle
Poêle aluminium manche en fer
Padella in alluminio manico en ferro
Aluminium-Bratfanne mit Eisengriff

REF.	Ø(mm)	h(mm)	€	UE / MOQ
8351	180	2,5	12,68	1-0-6-54-324 / 12
8352	200	3,5	16,12	1-0-6-36-324 / 12
8353	220	3,5	18,55	1-0-6-30-240 / 12
8354	240	3,5	21,60	1-0-6-24-216 / 6
8355	260	4	26,12	1-0-6-24-216 / 6
8356	280	4	28,35	1-0-6-24-192 / 6
8357	320	4	35,05	1-0-6-12-96 / 6
8358	360	4	41,27	1-0-6-12-84 / 6
8359	400	4	49,96	1-0-6-12-96 / 6



FUJI

Sartén inox mango inox
Frypan inox
Poêle à frir inox
Padella inox
Inox-Bratfanne

REF.	Ø(mm)	h(mm)	€	UE / MOQ
8515	200	0,7	26,45	1-0-6-36-288 / 1
8516	240	0,7	31,22	1-0-6-24-192 / 1
8517	280	0,7	39,44	1-0-6-24-192 / 1
* 8518	320	1	57,59	1-0-4-8-64 / 1
* 8519	360	1	69,08	1-0-4-4-24 / 1
* 8520	400	1	82,48	1-0-4-4-28 / 1



USSON

Sartén aluminio mango hierro / Inducción
Aluminium induction fry pan with inox handle
Poêle induction aluminium manche en inox
Padella induzione in alluminio manico in inox
Induktion aluminium-Bratfanne mit inoxgriff induktion

REF.	Ø(mm)	h(mm)	€	UE / MOQ
8958	200	3	18,61	1-0-6-36-324 / 6
8959	240	3	23,52	1-0-6-24-216 / 6
8960	280	3	27,59	1-0-6-24-192 / 6
8961	320	3	33,05	1-0-6-12-96 / 6



VESUVIO

Sartén inox antiadherente mango inox
Frypan, non stick coating
Poêle avec revêtement anti-adhésif
Padella inox antiaderente
Bratfanne mit Antihafbeschichtung

REF.	Ø(mm)	h(mm)	€	UE / MOQ
8509	200	0,7	34,98	1-0-6-36-288 / 1
8510	240	0,7	43,05	1-0-6-24-192 / 1
8511	280	0,7	53,18	1-0-6-24-144 / 1
* 8512	320	1	71,13	1-0-4-8-64 / 1
* 8513	360	1	86,80	1-0-4-4-28 / 1
* 8514	400	1	104,76	1-0-4-4-28 / 1

Cocina / Kitchen
CROSCAT COLLECTION

Cocción / Gama Croscat
Cooking / Croscat Range

Nuestra colección CROSCAT está diseñada para satisfacer las exigencias de la cocina profesional, con una batería de servicio que incluye todas las piezas esenciales para la preparación de recetas perfectas.

Our CROSCAT collection is designed to meet the demands of the professional kitchen, with a service set that includes all the essential pieces for the preparation of perfect recipes.



Descubre la
gama de bate-
rías y sartenes.



SARTÉN HONDA DEEP PAN

Axa adicional en diámetros grandes. Additional handle on large diameters.

Sartén aluminio antiadherente alta mango inox
Deep frypan, non stick coating
Poêle avec revêtement anti-adhésif
Padella inox antiaderente
Bratpfanne mit antihafbes

REF.	Ø(mm)	Ø(mm)	H(mm)	€	UE / MOQ
10897	240	3	70	23,55	1-0-6-24-144 / 6
10898	280	3	75	28,40	1-0-6-24-144 / 6
10899	320	3	80	34,03	1-0-6-18-108 / 6
11599	360	3	80	45,29	1-0-4-0-0 / 4 *
11601	400	3	90	52,36	1-0-4-0-0 / 4 *

NEW
NEW



NEW

Cazo Recto
Straight Ladle
Casserole Droite
Mestolo Dritto
Stieltopf

REF.	Ø(mm)	Ø(mm)	H(mm)	LITROS	€	UE / MOQ
11789	140	3	68	0,95	16,56	1-0-6-0-0 / 6
11790	160	3	76	1,4	18,79	1-0-6-0-0 / 6
11791	180	3	85	2	21,12	1-0-6-0-0 / 6
11792	200	3	98	2,88	24,08	1-0-6-0-0 / 6



NEW

Olla
Saucepan
Casserole
Pentola
Topf

REF.	Ø(mm)	Ø(mm)	H(mm)	LITROS	€	UE / MOQ
11780	200	3	140	4,18	27,48	1-0-4-0-0 / 4
11781	240	3	150	6,46	34,76	1-0-4-0-0 / 4
11782	280	3	170	9,98	42,63	1-0-4-0-0 / 4
11951	300	3	180	12,22	49,67	1-0-4-0-0 / 4
11952	320	3	185	14,32	53,79	1-0-4-0-0 / 4



NEW

Cacerola
Casserole
Fait-Tout
Casseruola
Stielkasserolle

REF.	Ø(mm)	Ø(mm)	H(mm)	LITROS	€	UE / MOQ
11787	240	3	100	4,25	29,18	1-0-4-0-0 / 4
11788	280	3	110	6,27	35,15	1-0-4-0-0 / 4
11953	300	3	120	8	41,65	1-0-4-0-0 / 4



NEW

Tapa Borosilicato
Borosilicate Lid
Couvercle Borosilicate
Coperchio In Vetro Borosilicato
Deckel Borosilikat Glasdeckel

REF.	Ø(mm)	€	UE / MOQ
11794	200	7,01	1-0-12-0-0 / 12
11795	240	7,57	1-0-12-0-0 / 12
11796	280	8,38	1-0-12-0-0 / 12
11954	300	8,93	1-0-12-0-0 / 12
11955	320	9,28	1-0-12-0-0 / 12



Cazuela aluminio
Aluminium casserole
Casserole aluminium
Casseruola in alluminio
Aluminiumkasserolle

REF.	Ø(mm)	Ø(mm)	H(mm)	€	UE / MOQ
11611	280	3	70	27,14	1-0-6-24-144 / 6
11612	320	3	80	32,58	1-0-6-18-108 / 6
11613	360	3	80	37,24	1-0-4-0-0 / 4
11615	400	3	90	44,52	1-0-4-0-0 / 4

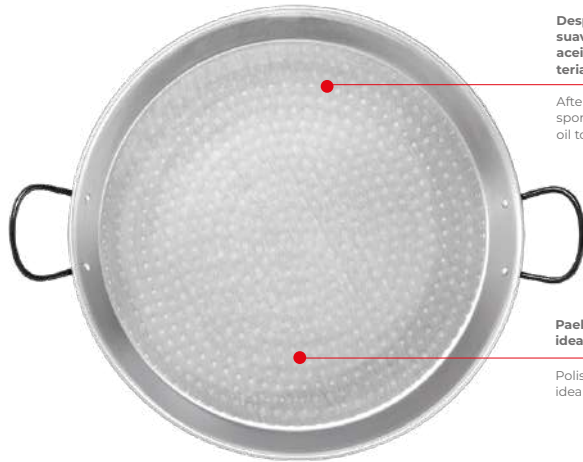

Después de usar lavar con esponja suave, secar y aplicar una capa de aceite de oliva para conservar el material.

After use, wash with a non-abrasive sponge, dry and apply a coat of olive oil to protect the material.

Paellera de acero pulido ideal para cocción de llama.

Polished steel paella pan, ideal for use over flame.



Paellera de acero con recubrimiento de esmalte que le proporciona una mayor resistencia al óxido.

Rust-resistant enamelled steel paella pan.

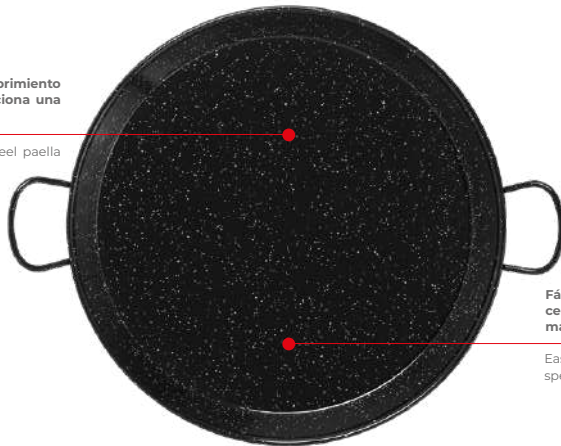

Fácil de limpiar y de almacenar, no precisan de un mantenimiento específico.

Easy to clean and store, no special care is required.





EL SALER

Paellera acero pulido
Polished steel spanish paella pan
Plat à paella toile acier
Padella valenciana lucida
Paellapfanne aus poliertem Stahl

REF.	Ø(cm)	Raciones	€	UE / MOQ
8964	30	4	9,82	1-0-6-24-144 / 1
8965	34	6	11,91	1-0-6-24-120 / 1
8966	38	8	14,69	1-0-6-12-60 / 1
8967	42	10	18,22	1-0-6-12-60 / 1
8968	46	12	21,45	1-0-4-8-48 / 1
8969	50	13	24,79	1-0-4-8-48 / 1
8970	60	20	46,68	1-0-4-4-24 / 1
10937	65	25	57,04	1-0-0-0-0 / 1
10938	70	30	75,04	1-0-0-0-0 / 1
10939	80	40	102,86	1-0-0-0-0 / 1
10940	90	50	142,39	1-0-0-0-0 / 1



RIBA ROJA

Paellera acero esmaltado
Enamelled steel paella pan
Plat à paella acier émaillé
Padella valenciana smaltata
Paellapfanne aus emailiertem Stahl

REF.	Ø(cm)	Raciones	€	UE / MOQ
8971	30	4	14,11	1-0-6-24-144 / 1
8972	34	6	16,97	1-0-6-24-120 / 1
8973	38	8	20,92	1-0-6-12-60 / 1
8974	42	10	27,76	1-0-6-12-60 / 1
8975	46	12	32,45	1-0-4-8-48 / 1
8976	50	13	37,86	1-0-4-8-48 / 1
8977	60	20	61,66	1-0-4-4-24 / 1

* También para raciones individuales.
Also for individual portions.
COLECCIÓN PELTRE (p.405)

Paellera grande acero pulido
Polished steel spanish paella pan
Plat à paella toile acier
Padella valenciana lucida
Paellapfanne aus poliertem Stahl

REF.	Ø(cm)	Raciones	€	UE / MOQ
10941	100	85	272,32	1-0-0-0-0 / 1
10942	115	120	339,11	1-0-0-0-0 / 1
10943	130	200	669,57	1-0-0-0-0 / 1

COMPATIBLE CON
COMPATIBLE WITH:
REF.: 10944 (p.314)



ALBUFERA

Sartén honda acero esmaltado
Deep enamelled fry pan with handles.
Poele haute avec anses.
Padella smaltata con manici.
Tiefe Paellapfanne aus emailiertem Stahl mit Griffen.

REF.	Ø(cm)	€	UE / MOQ
8978	28	12,14	1-0-6-24-120 / 1
8979	32	16,92	1-0-6-24-120 / 1
8980	36	20,68	1-0-4-8-40 / 1
8981	40	25,70	1-0-4-8-40 / 1
8982	45	35,61	1-0-3-6-30 / 1
8983	50	47,13	1-0-3-6-30 / 1



Tripode regulable para quemador
Base for burner
Pied pour bruleur
Treppiede padella
Dreifußständer für Gasbrenner

REF.	W(cm)	H(cm)	€	UE / MOQ
8984	300	300	46,10	1-0-1-3-9 / 1



Paravientos 3 piezas
Windshield
Pare-bris 3 pieces
Paravento 3 pezzi
Windschutzblech

REF.	W(cm)	H(cm)	€	UE / MOQ
8505	670	160	45,01	1-0-1-6-96 / 1



Quegador paellero a gas
Enamelled gas burner
Brûleur émaillé
Bruciatore smaltato padella
Emailliert Gasbrenner



REF.	Ø(cm)	PARA PAELLERAS	€	UE / MOQ
8985	30	36 - 42CM	39,74	1-0-1-4-24 / 1
8986	40	26 - 60CM	70,04	1-0-1-3-12 / 1
8987	50	36 - 70CM	82,48	1-0-1-2-10 / 1

Quegador de cocción para uso doméstico y/o profesional. Fabricado en acero y recubierto de una capa de esmalte. Diseñado para ser utilizado en el exterior.

Burner for domestic or professional use. Made of enamelled steel. Designed for outdoor use.



Este producto está certificado según la normativa de gas vigente. Conexión roscada especial para Gas Natural.

También disponible bajo demanda para otras conexiones europeas.

This product has been certified under the law relating to gas appliances. Threaded Natural Gas connector.

Available on request to fit other European connectors.



Quegador paellero a gas grande
Enamelled gas burner
Brûleur émaillé
Bruciatore smaltato padella
Emailliert Gasbrenner

REF.	Ø(cm)	€	UE / MOQ
10944	90	841,00	1-0-0-0-0 / 1

* Tripode incluido.
Funciona con 2 botellas de butano o propano.

Tripod included.
Works with 2 butane or propane bottles.





Conoce AMT y condiciones de venta en la página: 520
 More about AMT and sales conditions in page: 520

Aluminio Fundido. Cast Aluminium.

Aluminio fundido de alta resistencia hecha por expertos artesanos. Gracias al espesor del aluminio, de los utensilios AMT almacenan más energía y mantiene la temperatura constante durante más tiempo.

Son resistentes a altas temperaturas sin ninguna alteración en su forma.

High-strength cast aluminium made by skilled craftsmen. Thanks to the thickness of the aluminium, AMT cookware stores more energy and maintains a constant temperature for longer.

They are resistant to high temperatures without any alteration in their shape.

Sostenibilidad. Sustainability.

AMT produce de una manera sostenible y respetuosa con el medio ambiente, proporcionando una selección consciente de los productos que va a utilizar durante mucho tiempo, al tiempo que **reduce significativamente su huella de carbono**.

El grosor de 9-10 mm del fondo de las sartenes y ollas garantiza una **gran transferencia de energía y retención del calor**. Esto nos permite aplicar cocciones de una manera más eficiente.

*AMT produced in a sustainable and environmentally friendly manner, providing a conscious selection of products that you will use for a long time, while **significantly reducing your carbon footprint**.*

*9-10 mm thick bottom of our pans and pots **ensures great energy transfer and heat retention**. This allows us to apply firings more efficiently.*

Superficie antiadherente. Non-stick surface.

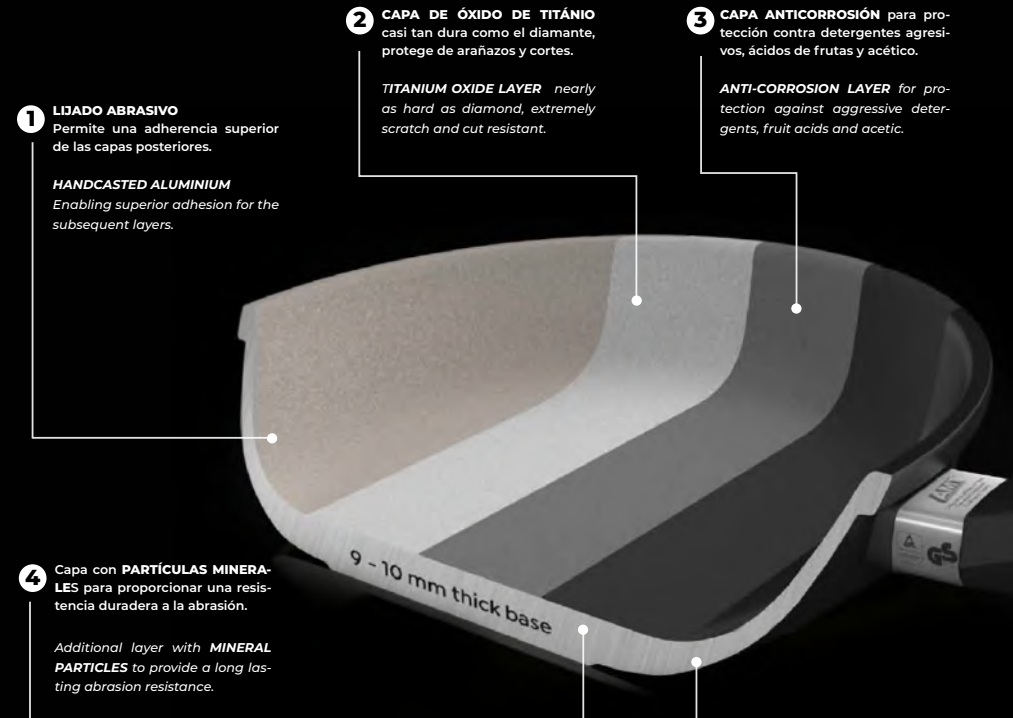

1 LIJADO ABRASIVO
 Permite una adherencia superior de las capas posteriores.

HANDCASTED ALUMINIUM
 Enabling superior adhesion for the subsequent layers.

2 CAPA DE ÓXIDO DE TITANIO
 casi tan dura como el diamante, protege de arañazos y cortes.

TITANIUM OXIDE LAYER nearly as hard as diamond, extremely scratch and cut resistant.

3 CAPA ANTICORROSIÓN para protección contra detergentes agresivos, ácidos de frutas y acético.

ANTI-CORROSION LAYER for protection against aggressive detergents, fruit acids and acetic.

4 Capa con PARTÍCULAS MINERALES para proporcionar una resistencia duradera a la abrasión.

Additional layer with **MINERAL PARTICLES** to provide a long lasting abrasion resistance.

5 Capa de REVESTIMIENTO ANTIADHERENTE, fabricada con el exclusivo sellado Lotan con efecto antibacteriano.

NON-STICK COATING layer, made from their unique Lotan sealing with anti-bacterial effect.



GASTRONORM COOKING

Múltiples soluciones para cocina profesional.
Multiple solutions for professional kitchens.

ESPECIAL HORNOS DE CONVECCIÓN SPECIAL CONVECTION OVENS

Recubrimiento antiadherente de alto rendimiento y de fácil limpieza.

High-performance, easy-to-clean non-stick coating.

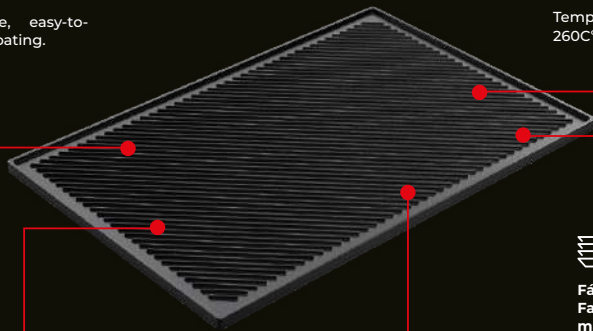

Apto para calentar en hornos de convección.

Suitable for heating in convection ovens.

Medidas GN 1/1 y 60x40cm compatibles con hornos de convección.

GN 1/1 and 60x40cm sizes compatible with convection ovens.



260 °C
Resiste a temperaturas de hasta 260°C°.

Temperature resistant up to 260°C°.



Fácil apilabilidad. Facilita el transporte y almacenamiento en buffet y cocinas profesionales.

Easy stackability. Easy transport and storage in buffets and professional kitchens.

AMT
GASTROGUS



Cocción gastronorm / Gastronorm cooking

Bandeja Gn 1/1 Grill & Pizza
Tray Gn 1/1 Grill & Pizza
Plateau Gn 1/1 Grill Et Pizza
Vassoio Gn 1/1 Grill & Pizza
Gn-Backblech 1/1 Grill Und Pizza

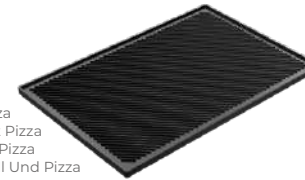

REF.	WxL(mm)	H(mm)	€	MOQ
11828	GN 1/1	20	229,79	1
11829	60x40	20	265,15	1

Bandeja Gn 1/1 Bbq Perforada
Tray Gn 1/1 Perforated Bbq
Plateau Gn 1/1 Bbq Perforé
Vassoio Gn 1/1 Perforato Da Barbecue
Gn-Backblech 1/1 Bbqmit Schlitzen



REF.	WxL(mm)	H(mm)	€	MOQ
11830	GN 1/1	20	271,04	1

Cesta Gn 1/1 Perforada
Gn Perforated Basket
Corbeille Gn 1/1 Perforée
Cestello Gn 1/1 Perforato
Gn-Korb Mit Löchern



REF.	WxL(mm)	H(mm)	€	MOQ
11840	GN 1/1	40	230,09	1

Bandeja Gn 1/1 Perforada
Gn Tray 1/1 Perforated
Plateau Perforé Gn 1/1
Vassoio Gn 1/1 Accatastabile
Gn-Backblech 1/1 Stapelbar



REF.	WxL(mm)	H(mm)	€	MOQ
11841	GN 1/1	30	133,34	1

Bandeja Gn 1/1 11 Moldes
Gn Tray 1/1 11 Moulds
Plateau Gn 1/1 11 Moules
Vassoio Gn 1/1 Stampi
Gn-Backblech 1/1 Formen



REF.	WxL(mm)	H(mm)	€	MOQ
11842	GN 1/1	50	180,06	1

Bandeja Multiuso Baker
Baker Tray, Utility
Plateau Multiusage Baker
Vassoio Multiuso Baker
Backblech mehrzweck Baker



REF.	WxL(mm)	H(mm)	€	MOQ
11843	GN 1/1	20	134,99	1
11844	60x40	20	142,35	1

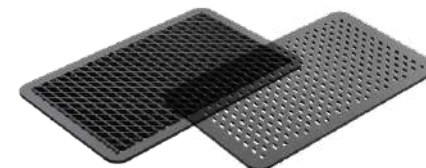

Bandeja Gn 1/1 Bbq & Smooth Perforada
Gn Tray 1/1 Bbq & Smooth, Perforated Plateau Gn 1/1 Bbq Et Smooth Perforé
Vassoio Gn 1/1 Bbq & Smooth Perforata Gn-Backblech 1/1 Bbq & Smooth Mit Schlitzen

REF.	WxL(mm)	H(mm)	€	MOQ
11839	GN 1/1	10	170,87	1

Cubeta Gn 1/1
Gn Container 1/1
Plateau Gn 1/1
Vassoio Gn 1/1
Gn-Behälter 1/1



REF.	GN	WxL(mm)	H(mm)	€	MOQ
11989	1/1	530x325	55	303,04	1
11990	1/1	530x325	100	350,10	1

GASTRONORM BUFFET

Cocinar y servir en un solo recipiente.
Cook and serve in a single container.



AMT
GASTROGLISS



Medidas disponibles
Available sizes:

GASTRONORM

1/1 1/2 1/3 2/3

ALTURAS / HEIGHTS:
2cm / 5,5cm / 10cm



Apto para cocción y regeneración en horno.

Suitable for cooking and regenerating in the oven.

Recipientes con asas para mayor comodidad en el transporte y presentación.

Containers with handles for convenient transport and presentation.



También disponible para inducción.

Also available for induction.

Diseñado para mantenimiento de calor en buffet (Chafing o placas de inducción).

Designed for holding heat on buffet (Chafing or induction hobs).



260 °C

Apta a altas temperaturas de hasta 260 °C sin alterar la forma, gracias a la resistencia del aluminio fundido.

Suitable for high temperatures up to 260 °C without altering the shape, thanks to the strength of the cast aluminium.



Cubeta Gn Con Asas / Inducción
Gn Container With Handles/Induc.
Plateau Gn Avec Poignées Induc.
Vassoio Gn Con Manici /Induz.
Gn-Behälte Mit Henkel/Induk.



Cubeta Gn Inducción
Gn Container Induc.
Plateau Gn Induc.
Vassoio Gn Induz.
Gn-Behälte Induk.

REF.	GN	WxL(mm)	H(mm)	€	MOQ
11862	1/1	530x325	55	468,19	1
11863	1/1	530x325	100	513,32	1
11854	1/2	265x325	55	331,73	1
11851	1/3	176x325	55	228,85	1
11852	1/3	176x325	100	243,58	1
11856	2/3	354x325	55	378,51	1

REF.	GN	WxL(mm)	H(mm)	€	MOQ
11861	1/1	530x325	55	389,65	1
11853	1/2	265x325	55	280,47	1
11855	2/3	354x325	55	299,91	1

Bandeja Gn Con Asas / Inducción
Gn Container With Handles/Induc.
Plateau Gn Avec Poignées Induc.
Vassoio Gn Con Manici /Induz.
Gn-Behälte mit Henkel/Induk.



Bandeja GN BBQ con asas
Brochette grill
Gril à brochette
Griglia per spiedini
Grill für Spieße



REF.	GN	WxL(mm)	H(mm)	€	MOQ
11859	1/1	530x325	20	440,14	1
11857	2/3	354x325	20	276,93	1

REF.	GN	WxL(mm)	H(mm)	€	MOQ
11860	1/1	530x325	20	440,14	1
11858	2/3	354x325	20	276,93	1

SPEED OVEN ACCESSORIES

Regeneración más rápida y eficiente.
Faster and more efficient regeneration.



SPEED OVEN

260 °C

Speed oven

EFICIENCIA. EFFICIENCY.

Distribución rápida y uniforme del calor en toda la superficie de los accesorios. Tiempos de cocción más cortos sin comprometer la calidad.

Fast and even heat distribution on the whole surface of accessories. Shorter cooking times without compromising quality.

UTILIDAD. UTILITY.

Productos perfectos para la cocción y regeneración de una manera más rápida y efectiva.

Perfect products for warming, browning and baking in fast service.

VARIEDAD. VARIETY.

Selección de accesorios de Speed Ovens para una mayor comodidad y seguridad según cada necesidad de operativa de servicio.

Selection of Speed Ovens accessories for convenience and safety according to each service operation need.

Pala Snacks
Snack Scoop
Spatule À Snaks
Paletta Per Snack
Snack-Schaufel



REF.	WxL(mm)	H(mm)	€	MOQ
11849	425x29	10	82,73	1

Cuenco Cuadrado Snacks
Square Pie Dish Snacks
Bol Carré À Snaks
Recipiente Quadrato Snacks
Quadratische Snack-Schüssel



REF.	WxL(mm)	H(mm)	€	MOQ
11850	245x15	50	70,82	1

Bandeja Cuadrada Lisa
Square Tray Smooth
Plateau Carré Lisse
Vassoio Quadrato Liscia
Quadratisches Superglatt



REF.	WxL(mm)	H(mm)	€	MOQ
11845	260x260	30	104,64	1

Bandeja Cuadrada Grill
Square Tray Grill
Plateau Carré Grill
Vassoio Quadrato Grill
Quadratisches Grill



REF.	WxL(mm)	H(mm)	€	MOQ
11846	260x260	30	106,18	1

Pinza
Tong
Pince
Pinza
Pinzette



REF.	L(mm)	€	MOQ
11847	200	60,54	1

Bandeja Cuadrada Grill
Square Tray Grill
Plateau Carré Grill
Vassoio Quadrato Grill
Quadratisches Backblech Grill

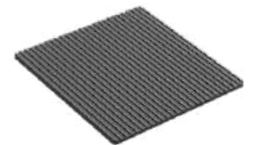

REF.	WxL(mm)	H(mm)	€	MOQ
11848	292x286	10	112,66	1

OTHERS

Cazuelas de alta capacidad.
High-capacity casseroles.



AMT
GASTROGUS

Otros / Others



260 °C

Soporta temperaturas de hasta 260 °C sin alterar la forma, gracias a la resistencia del aluminio fundido.

Withstands temperatures of up to 260°C without altering shape, thanks to the strength of the cast aluminium.



Conductividad térmica más eficiente gracias al aluminio fundido de 4 mm de grosor.

More efficient thermal conductivity thanks to 4 mm thick cast aluminium.



Superficie antiadherente. De 3 a 4 capas de revestimiento antiadherente y anticorrosión

Non-stick surface. 3 to 4 layers of non-stick and anti-corrosion coating.



Apto para cocción y para calentar en horno.

Suitable for baking and heating in the oven.



Apto para placas de inducción.

Suitable for induction hobs.



Mantiene una temperatura constante por un largo tiempo en toda las superficies.

Maintains a constant temperature for a long time on all surfaces.

Cazuela Gran Capacidad
Stock Pot
Casserole Grande Capacité
Casseruola Grande Capacita'
Grosser Schmortopf



REF.	Ø(mm)	H(mm)	€	MOQ
11831	380	70	197,50	1

Cazuela Gran Capacidad
Stock Pot
Casserole Grande Capacité
Casseruola Grande Capacita'
Grosser Schmortopf



REF.	Ø(mm)	H(mm)	€	MOQ
11832	50	80	326,48	1
11834	65	80	612,31	1
11837	80	100	1.027,83	1

Cazuela Gran Capacidad 2 segm.
Stock Pot
Casserole Grande Capacité
Casseruola Grande Capacita'
Grosser Schmortopf



REF.	Ø(mm)	H(mm)	€	MOQ
11833	50	80	405,91	1
11835	65	80	679,07	1

Cazuela Gran Capacidad 3 segm.
Stock Pot
Casserole Grande Capacité
Casseruola Grande Capacita'
Grosser Schmortopf



REF.	Ø(mm)	H(mm)	€	MOQ
11836	65	80	718,25	1
11838	80	100	1.146,91	1



La cuidadosa selección de nuestros materiales: Aluminio fundido a presión.
The careful selection of our materials: Die-cast aluminium.



Seleccionamos cuidadosamente las técnicas y los materiales más avanzados para crear nuestros productos. El uso exclusivo de aluminio fundido a presión (una materia prima certificada para uso alimentario) proporciona una distribución óptima y constante del calor, así como una gran resistencia a los diferentes métodos de cocción y un proceso de cocción más natural

We carefully select the most advanced techniques and materials to create our products. The exclusive use of die-cast aluminium (a raw material certified for food use) provides an optimal and constant heat distribution, as well as a high resistance to different cooking methods and a more natural cooking process.

Cocción homogénea.
Homogeneous cooking.

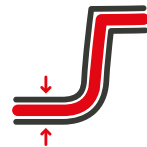

El aluminio fundido a presión tiene excelentes propiedades de conducción del calor y los alimentos se cocinan de manera uniforme sin que se quemen ni se altere su sabor, manteniendo las propiedades nutritivas en cada tipo de alimento.

The die-cast aluminium has excellent heat conduction properties and the food cooks evenly without burning or altering its taste, maintaining the nutritional properties in each type of food.

El aluminio está fundido a presión con un grosor considerable que distribuye el calor de manera uniforme y una base resistente a la deformación.

The aluminium is die-cast with a considerable thickness that distributes heat evenly and a base that is resistant to deformation.

No pierde calor, lo que permite ahorrar energía. Incluso cuando se apaga la fuente de calor, mantiene la temperatura durante otros 10/15 minutos manteniendo los alimentos calientes mientras se sirven en la mesa.

It doesn't lose heat, which saves energy. Even when the heat source is turned off, it maintains the temperature for another 10/15 minutes keeping the food warm while it's being served at the table.



ELDIAMANT[®]
PROFILE

La gama BLACKplus incluye en exclusiva el revestimiento ELDIAMANT PROFILE de última generación, capaz de garantizar una resistencia a las rayadas sin precedentes en los recubrimientos antiadherentes. El cuerpo en aluminio fundido de alto espesor para obtener ligereza, indeformabilidad y mejor distribución del calor, ELDIAMANT PROFILE con partículas minerales para cocinar sin aceite.

The BLACKplus range exclusively includes the latest generation ELDIAMANT PROFILE coating, capable of guaranteeing unprecedented scratch resistance in non-stick coatings. The high thickness cast aluminium body for lightness, non-deformability and better heat distribution, ELDIAMANT PROFILE with mineral particles for oil-free cooking.



40.000
ciclos de uso.



La garantía del producto es de (2+1 años) desde el momento de la compra (presentando el comprobante) y si se respetan las instrucciones de uso. RisolÍ no se hace responsable de daños causados por un incorrecto uso del producto.

The product is guaranteed (2+1 years) from the moment of purchase (presenting the receipt) and if the instructions for use are followed. RisolÍ is not responsible for any damage caused by incorrect use of the product.

Cocina / Kitchen



Espeor 6 - 7 mm

6 - 7 mm thickness.

Mango de acero inoxidable 18/10 termoaislante con 4 remaches.

Stainless steel handle 18/10 heat protection with 4 rivets.

Revestimiento interior Teflon Profile antiadherente resistente al rayado.

Inside non stick coating Teflon Platinum scratch resistant.

Garantía ECOCAST 3 años.

3 years ECOCAST guarantee.



INOX STAINLESS STEEL 304

Sartén fusa 18/10
Frypan Fusa 18/10
Poêle fusa 18/10
Padella fusa 18/10
Pfanne fusa 18/10

ALUMINIO FUNDIDO
CAST ALUMINIUM

REF.	Ø(mm/inches)	E(mm)	L(mm)	€	MOQ
10000	240/9,4"	0,6	50	89,73	1
10001	280/11"	0,6	52	106,48	1
10002	320/12,5"	0,6	58	118,05	1



INOX STAINLESS STEEL 304

Sartén honda fusa 18/10
Deep frypan Fusa 18/10
Poêle profonde fusa 18/10
Padella profonda fusa 18/10
Tiefe pfanne fusa 18/10

ALUMINIO FUNDIDO
CAST ALUMINIUM

REF.	Ø(mm/inches)	E(mm)	L(mm)	€	MOQ
10004	240/9,4"	0,6	70	97,44	1
10005	280/11"	0,6	70	114,20	1
10006	320/12,5"	0,6	80	127,97	1
10007	360/14"	0,6	80	153,58	1

RISOLI
IL PRESSOFUSO IN CUCINA

Aluminio Fundido / Cast Aluminium



FONDO: Alto espesor para una perfecta difusión del calor.

BOTTOM: High thickness for perfect heat diffusion.

Apto para cocinas de gas, eléctricas, vitrocerámicas y horno.

Suitable for gas, electric, glass-ceramic, oven and induction cookers.

Diseño innovador y exclusivo para un agarre seguro.

Innovative and exclusive design for a secure grip.

Remache exterior especial.

Special external rivet.

Sartén Classica



INOX STAINLESS STEEL 304

Sartén Classica
Frypan Classica
Poêle Classica
Padella Classica
Pfanne Classica

ALUMINIO FUNDIDO
CAST ALUMINIUM

REF.	Ø(mm/inches)	E(mm)	L(mm)	€	MOQ
10008	240/9,4"	0,6	50	85,08	1
10009	280/11"	0,6	52	99,02	1
10010	320/12,5"	0,6	58	11,30	1
10011	360/14"	0,6	60	125,42	1



INOX STAINLESS STEEL 304

Sartén honda Classica
Deep frypan Classica
Poêle profonde Classica
Padella profonda Classica
Tiefe pfanne Classica

ALUMINIO FUNDIDO
CAST ALUMINIUM

REF.	Ø(mm/inches)	E(mm)	L(mm)	€	MOQ
10012	240/9,4"	0,6	70	92,27	1
10013	280/11"	0,6	70	106,30	1
10014	320/12,5"	0,6	80	119,46	1
10015	360/14"	0,6	80	139,54	1

Sartén Ergo



MANGO
BAQUELITA
BAKELITE
HANDLE
200°C



Sartén Ergo Prof
Frypan Ergo Prof
Poele Ergo Prof
Padella Ergo Prof
Pfanne Ergo Prof

ALUMINIO
FUNDIDO
CAST
ALUMINIUM

REF.	Ø(mm)/inches	ml	e(mm)	L(mm)	€	MOQ
10016	200/7,8"	0,7	50		76,74	1
10017	240/9,4"	0,7	52		90,34	1
10018	280/11"	0,7	58		103,85	1
10019	320/12,5"	0,7	60		130,07	1



Sartén honda Ergo Prof
Deep frying pan Ergo Prof
Poele profonda Ergo Prof
Padella profonda Ergo Prof
Tiefe pfanne Ergo Prof

ALUMINIO
FUNDIDO
CAST
ALUMINIUM

REF.	Ø(mm)/inches	ml	e(mm)	L(mm)	€	MOQ
10020	240/9,4"	200	0,9	80	99,37	1
10021	280/11"	300	0,9	85	116,13	1



Whitford

Grill mango silicona abatible
Grill "xl" silicone handle
gril manche rabattable
griglia maniglie estraibile
gril ausziehbar griff



REF.	WxL(mm)	ml	e(mm)	H(mm)	€	MOQ
10811	260x330	-	0,6	50	68,00	1



Disponibile en 3 colores
Available in 3 colours



Plancha burger
Burger griddle
Plancha burger
Piastra burger
Grillplatte burger

Whitford

REF.	WxL(mm)	ml	e(mm)	H(mm)	€	MOQ
10073	400x240	-	0,6	30	79,36	1

MANGO
BAQUELITA
BAKELITE
HANDLE
200°C



Grill asa BK
Grill BK handle
Gril asa BK
Griglia manico BK
Grillgriff BK



REF.	Ø(mm)/inches	ml	e(mm)	H(mm)	€	MOQ
10044	260x260	-	0,7	40	85,69	1

MANGO
BAQUELITA
BAKELITE
HANDLE
200°C



Wok mango BK
Wok BK handle
Wok manche BK
Wok maniglie BK
Wok Griff BK



REF.	Ø(mm)/inches	ml	e(mm)	H(mm)	€	MOQ
10057	300/11,8"	-	0,6	90	94,20	1



Whitford

Huevo & dulce
Egg & sweet
Oeuf & sucré
Uovo e dolce
Ei & süß



**PORCIÓN
INDIVIDUAL
INDIVIDUAL
PORTION**

REF.	Ø (mm/inches)	ml	e (mm)	L (mm)	€	MOQ
10022	140/5,5"	-	0,5	30	29,29	1



Mini cacerola
Mini saucepan
Mini casserole
Mini casseruola
Mini kasserolle



COMPATIBLE CON (p.327)

10064 - 10065



REF.	Ø (mm/inches)	ml	e (mm)	H (mm)	€	MOQ
10023	160/6,2"	100	0,5	68	51,75	1
10024	200/7,8"	150	0,5	70	57,71	1



Cacerola alta grand gourmet
Grand gourmet high saucepan
Casserole haute grand gourmet
Casseruola alta grand gourmet
Hohe Kasserolle grand gourmet



COMPATIBLE CON (p.327)

10065 - 10066 - 10067



REF.	Ø (mm/inches)	ml	e (mm)	L (mm)	€	MOQ
10031	200/7,8"	250	0,6	105	69,82	1
10032	240/9,44"	350	0,6	106	84,11	1
10033	280/11"	450	0,6	110	108,41	1

Horno / Especial Oven / Special

Whitford

Mini finger grill
Mini finger grill
Mini finger grill
Mini finger griglia
Mini finger grillpfanne



**PORCIÓN
INDIVIDUAL
INDIVIDUAL
PORTION**

REF.	WxL (mm/inches)	e (mm)	H (mm)	€	MOQ
10025	320x160/126x6,2"	0,5	30	44,56	1



Cacerola grand gourmet
Grand gourmet saucepan
Casserole grand gourmet
Casseruola grand gourmet
Kasserolle grand gourmet



COMPATIBLE CON (p.327)

10066 - 10067 - 10068 - 10069



REF.	Ø (mm/inches)	ml	e (mm)	L (mm)	€	MOQ
10027	240/9,4"	200	0,6	70	59,77	1
10028	280/11"	300	0,6	75	73,63	1
10029	320/12,5"	450	0,6	85	85,76	1
10030	360/14,1"	550	0,6	85	114,78	1



Cazo 1 mango grand gourmet
Grand gourmet pot 1 handle
Casserole 1 manche grand gourmet
Casseruola 1 mangico grand gourmet
Kasserolle 1 griff grand gourmet



**MANGO
BAQUELITA
BAKELITE
HANDLE
200°C**

COMPATIBLE CON (p.327)

10064



REF.	Ø (mm/inches)	ml	e (mm)	L (mm)	€	MOQ
10034	160/6,2"	150	0,5	102	51,75	1

Aluminio Fundido / Cast Aluminium



Le Pignatte

Cocción lenta / Slow Cooking



Le Pignatte®



Más fácil de limpiar
Easier to clean



Más ligera que el hierro fundido
Lighter than cast iron



Mejor presentación
Better performance



Cacerola de cocción lenta "Le Pignatte"
Slow cooking saucepot "Le Pignatte"
Casserole à la mijoteuse "Le Pignatte"
Casseruola a cottura lenta "Le Pignatte"
Kasserolle langsamen Kochen "Le Pignatte"

REF.	Ø (mm/inches)	ml	e (mm)	L (mm)	€	MOQ
10035	200/7,8"	225	0,7	101	153,40	1
10036	240/9,4"	350	0,7	106	175,24	1
10037	280/11"	450	0,7	114	196,82	1

El pomo aguanta temperatura de hasta 200°C
The knob withstands temperatures up to 200°C.



200°C

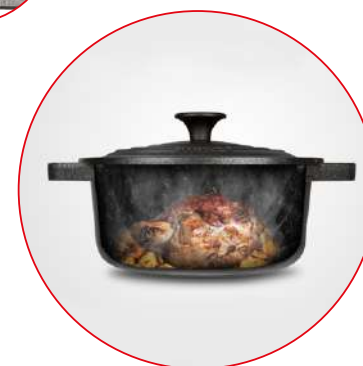

Horno / Especial Oven / Special



Ondulación para una mayor circulación del aire en el horno.

Undulation for greater air circulation in the oven.

Whitford

Grill pizza
Grill pizza
Gril pizza
Griglia pizza
Grill pizza



REF.	WxL(mm)	ml	e(mm)	H(mm)	€	MOQ
10041	400x340	-	0,8	30	94,20	1

COMPATIBLE
CALIU

Whitford

Grill para pinchos
Brochette grill
Gril à brochette
Griglia per spiedini
Grill für spieße



REF.	WxL(mm)	ml	e(mm)	H(mm)	€	MOQ
10040	470x260	-	0,6	50	91,04	1

46 X 25 CM

31 X 25 CM

Whitford

Plancha grill
Servigrill
Plaque de grill
Piastra grigliata
Grillplatte



REF.	WxL(mm)	ml	e(mm)	H(mm)	€	MOQ
10042	460x250	-	0,6	30	110,34	1
10735	460x250	-	0,6	30	110,98	1



Grill barbacoa
Grilled barbecue
Gril barbecue
Piastra barbecue
Grill grillen



REF.	WxL(mm)	ml	e(mm)	H(mm)	€	MOQ
10038	380x265	-	0,6	20	83,94	1

Whitford

Placa grill doble
Dual grill plate
Plaque de grill double
Piastra dual grill
Doppelte grillplatte



REF.	WxL(mm)	ml	e(mm)	H(mm)	€	MOQ
10071	300x225	-	0,5	20	48,13	1

Whitford

Grill horno
Oven grill
Gril four
Griglia forno
Grill ofen



REF.	WxL(mm)	ml	e(mm)	H(mm)	€	MOQ
10072	360x180	-	0,5	18	49,50	1

Aluminio Fundido / Cast Aluminium



Parrilla



Grill ovalado para pescado
Oval fish grill
Grill à poisson ovale
Pesciera ovale
Ovale Fischpfanne



REF.	WxL(mm)	ml	€	MOQ
10039	460x265	-	73,15	1



COMPATIBLE
CALIU

Rustidera
Lasagna pan
Plat à rôtir
Rostiera
Lasagneform



REF.	WxL(mm)	ml	€	MOQ
11604	400x250	5700	135,34	1



Tapa vidrio
 Glass Lid
 Couvercle verre
 Coperchio vetro
 Glasdeckel

REF.	Ø(mm/inches)	€	MOQ
BOROSILICATO			
10064	160/6,2"	12,98	1
10065	200/7,8"	17,98	1
10066	240/9,4"	19,30	1
10067	280/11"	23,15	1
10068	320/12,5"	25,08	1
VIDRIO TEMPLADO			
10069	360/14,1"	24,30	1



Disco inductor universal
 Universal inductor disc
 Disque inducteur universel
 Disco induttore universale
 Universal-induktorscheibe

REF.	Ø(mm)	ml	€	MOQ
10070	260	-	56,62	1



Salvamantel silicóna verde
 Silicone trivet green
 Sottopivetto in silicóna verde
 Dessous de plat silicóna vert
 Untersatz aus silikon grün

REF.	WxL(mm)	H(mm)	€	MOQ
10813	170x170	30	14,06	4
10814	190x190	30	25,69	4



Set 2 agarraderas silicóna negro
 Set 2 silicone handle black
 Set 2 manici in silicóna nero
 Set 2 manche en silicóna noir
 Set 2 silikongriff schwarz

REF.	€	MOQ
10812	20,64	4



MOLDE PARA HORNEAR REPOSTERÍA CREATIVA
BAKING MOLD FOR CREATIVE CAKES



**EXCELENTE
ANTIADHERENTE**
EXCELLENT
NON-STICK



**GRAN ESPESOR,
ROBUSTO**
EXTRA THICK,
EXTREME HARD



**PARA TARTAS
CREATIVAS**
FOR CREATIVE
CAKES

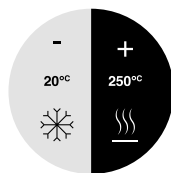

**PERFECTO
DE -20° A 250°**
PERFECT FROM
-20° TO 250°C

Black Plus[®]
ELDIAMANT[®]
PROFILE

Los fondos extragrosos y los revestimientos antiadherentes de los moldes garantizan no solo el horneado, gracias a su correcta conducción del calor, sino también asegura que mantengan mejor su forma que otros moldes similares, haciéndolos perfectos también para servir en la mesa.

Extra thick bottoms and non-stick coatings guarantee not just even baking thanks to correct heat conduction, but also ensure the tins keep their shape better than others on the market, making them perfect also for serving at the table.



ROYAL D'ALÙ. DESDE 1965.

Diseño: Mínima 2020
Design: Minimal 2020

Material: Aluminio fundido - hecho a mano
Material: Cast Aluminium - Handmade

Capa: Verde, Granito, Perfil
Coating: Green, Granito, Profile

Garantía: 2 años
Warranty: 2 years



Tarta de plato hondo "crostata" 4/6 personas
Deep dish tart "crostata" 4/6 people
Tarte creuse "crostata" 4/6 personnes
Crostata 4/6 persone
Deep dish torte "crostata" 4/6 personen

REF.	Ø(mm/inches)	ml	€	MOQ
10062	240	200	54,03	1



Tarta de plato hondo "ciambellone" 6/8 personas
Tartelette "ciambellone" 6/8 personnes
Tartelette "ciambellone" 6/8 personnes
Ciambellone con foro 6/8 persone
"Ciambellone"-torte 6/8 personen

REF.	Ø(mm/inches)	ml	€	MOQ
10063	260	200	65,61	1



Sartén pancake con mango BK
Pancake frypan with BK handle
Poêle pancake avec manche BK
Padella pancake manico BK
Pfanne pancake mit BK-griff

REF.	Ø(mm/inches)	ml	e(mm)	H(mm)	€	MOQ
10060	250/9,8"	-	65	25	77,97	1



Sartén creps con mango BK
Crepe frying pan with BK handle
Crêpe poêle avec manche BK
Crepe padella manico BK
Pfanne Krepp mit BK-griff

REF.	Ø(mm/inches)	ml	e(mm)	H(mm)	€	MOQ
10061	280/11"	-	65	23	98,23	1

Descubre
la plancha
grill GN.



Estructura de placa de aleación de aluminio con conductividad térmica muy alta e indeformable.

Aluminium alloy plate structure with very high thermal conductivity and non-deformable.

Certificado antiadherente de alta calidad.

High quality non-stick certificate.

Zonas de desague de cocina para no mezclar los sabores.

Kitchen drainage areas so as not to mix flavours.

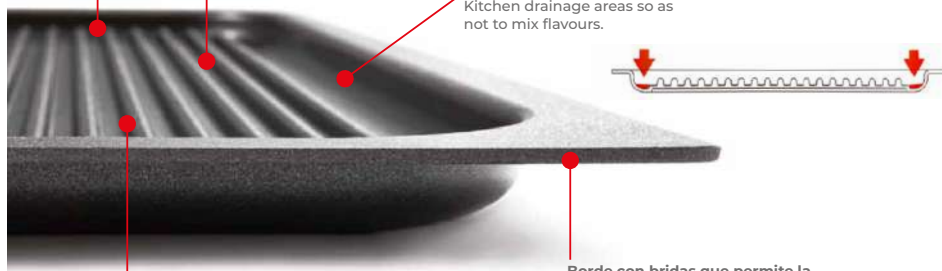

Rayadura y relieves para evitar el efecto fritura.

Scratches and reliefs to avoid the frying effect.

Borde con bridas que permite la inserción en el bastidor del horno.

Flanged edge for insertion into the oven frame.



* Nicola Ostinelli
Proprietario del ristorante Il Diavolo
L'acqua Santa



Plancha grill GN
GN grill
Plaque de cuisson GN
Piastra Griglia GN
Grill Platte GN

REF.	WxL(mm)	GN	e(mm)	H(mm)	€	MOQ
10045	530x325	1/1	0,7	20	270,14	1
11603	235x530	2/3	0,7	20	114,01	1

Cocción / Gastronorm
Cooking / Gastronorm

CUBETA GN EN ALUMINIO CON ANTIADHERENTE HARD STONE
Aluminium Baking Pans With non-stick coating

**ANTIADHERENTE
HARD-STONE**
MASSIMA ANTIADERENZA - MAGGIORE DURATA



GN 1/1

REF.	WxL(mm)	ml	e(mm)	H(mm)	€	MOQ
10046	530x325	-	1,5	20	62,54	1
10047	530x325	-	1,5	40	69,82	1
10048	530x325	-	1,5	65	82,80	1

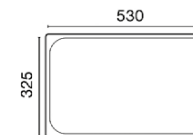

**ANTIADHERENTE
HARD-STONE**
MASSIMA ANTIADERENZA - MAGGIORE DURATA



GN 2/3

REF.	WxL(mm)	ml	e(mm)	H(mm)	€	MOQ
10049	355x325	-	1,5	20	46,31	1
10050	355x325	-	1,5	40	51,75	1
10051	355x325	-	1,5	65	60,78	1

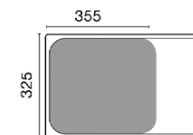

**ANTIADHERENTE
HARD-STONE**
MASSIMA ANTIADERENZA - MAGGIORE DURATA



GN 1/2

REF.	WxL(mm)	ml	e(mm)	H(mm)	€	MOQ
10052	265x325	-	1,5	20	38,24	1
10053	265x325	-	1,5	40	42,63	1

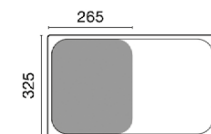



ELDIAMANT[®]
PROFILE

Rustidera

Lasagna pan
Plat à rôtir
Rostiera
Lasagneform



COMPATIBLE
CALIU

ALUMINIO
FUNDIDO
CAST
ALUMINIUM

REF.	LxW (mm)	€	MOQ
11604	250x400	135,34	1



Sartén BBQ

BBQ frypan
Poêle BBQ
Padella BBQ
Panne BBQ



REF.	Ø (mm/inches)	ml	e (mm)	H (mm)	€	MOQ
10058	320/11"	-	6	58	136,13	1



Paellera BBQ

Paella pan BBQ
Poêle à paella BBQ
Paellera BBQ
Paella-panne BBQ



REF.	Ø (mm/inches)	ml	e (mm)	H (mm)	€	MOQ
10059	320/11"	-	6	58	136,13	1



Paellera mango inox

Inox handle saucepan
Poêle à manche inox
Paellera manico inox
Bratpfanne mit Edelstahlgriff



REF.	Ø (mm/inches)	ml	e (mm)	H (mm)	€	MOQ
10054	280/11"	150	6	48	106,54	1
10055	320/12,5"	250	6	52	120,73	1
10056	360/14,1"	350	6	58	135,73	1



Grill para pinchos

Brochette grill
Gril à brochette
Griglia per spiedini
Grill für spieße



COMPATIBLE
CALIU

REF.	WxL (mm)	e (mm)	H (mm)	€	MOQ
10040	470x260	6	50	91,04	1

Grill horno

Oven grill
Gril four
Griglia forno
Grill ofen



REF.	WxL (mm)	e (mm)	H (mm)	€	MOQ
10072	360x180	5	18	49,50	1

Plancha grill GN

GN grill
Plaque de cuisson GN
Piastra Griglia GN
Grill Platte GN



SIZE
1/1
GN

SIZE
2/3
GN

REF.	WxL (mm)	GN	e (mm)	H (mm)	€	MOQ
10045	530x325	1/1	0,7	20	270,14	1
11603	235x530	2/3	0,7	20	114,91	1

Accesorios BBQ / BBQ Accessories

Grill barbecue

Grilled barbecue
Gril barbecue
Piastra barbecue
BBQ grill

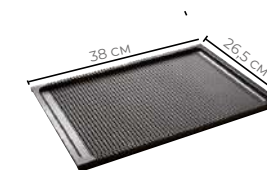

REF.	WxL (mm)	e (mm)	H (mm)	€	MOQ
10038	380x265	6	20	83,94	1

Placa grill doble

Dual grill plate
Plaque de gril double
Piastra dual grill
Doppelte grillplatte



REF.	WxL (mm)	e (mm)	H (mm)	€	MOQ
10071	300x225	5	20	48,13	1

Cocina / Kitchen

Certificado
contacto
alimentario.



Nuestras cubetas GN de acero AISI 304 son compatibles con las principales marcas GASTRONORM.

El radio de las esquinas más abierto permite una mejor y más fácil apilabilidad y optimiza la capacidad de las cubetas.

Our AISI 304 steel GN trays are compatible with the main GASTRONORM brands.

The more open corner radius allows for better and easier stackability and optimises the capacity of the trays.



Alta calidad garantizada.
High quality guaranteed.



Resistencia a la corrosión.
Corrosion resistance.



Máxima capacidad.
Maximum capacity.

Gastronorm / Cubetas Gastronorm / Cubetas

Tamaños GN / GN Sizes:

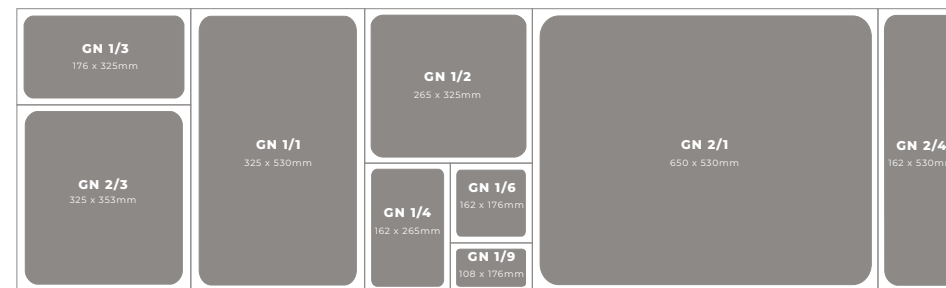

*medidas exteriores / external dimensions

Altura GN / GN High:



Apto horno.
Oven save.



Apto lavavajillas.
Dishwasher save.



Apilable.
Stackable.



-20°C
300 °C



Apto contacto
alimentario.
Food contact save.



COMPATIBLE CON LAS PRINCIPALES MARCAS DEL MERCADO
COMPATIBLE WITH THE MAIN BRANDS ON THE MARKET



El radio de las esquinas más abierto permite una mejor y más fácil apilabilidad y optimiza la capacidad de las cubetas.

The more open corner radius allows for better and easier stackability and optimises the capacity of the trays.

GN 1/1 - 325 X 530 mm



REF.	H(mm)	e(mm)	LT	€	UE / MOQ
10147	20	0,7		17,66	1-0-6-24-120 / 6
10148	40	0,7		20,75	1-0-6-24-120 / 6
10149	55	0,7		23,65	1-0-6-24-120 / 6
10150	65	0,8	8,8	23,61	1-0-6-24-120 / 6
11089	65	0,7	8,8	17,66	1-0-6-24-120 / 6
10151	100	0,7	13,7	30,45	1-0-6-24-120 / 6
10153	150	0,7	20	40,13	1-0-6-24-120 / 6
10154	200	0,7	27,8	49,54	1-0-6-24-120 / 6

GN 1/2 - 265 X 325 mm



REF.	H(mm)	e(mm)	LT	€	UE / MOQ
10164	20	0,7		9,45	1-0-6-24-120 / 6
10166	40	0,7		11,53	1-0-6-24-120 / 6
10168	65	0,7	8,8	14,11	1-0-6-24-120 / 6
10170	100	0,7	13,7	18,95	1-0-6-24-120 / 6
10172	150	0,7	20	25,27	1-0-6-24-120 / 6
10173	200	0,7	27,8	36,06	1-0-6-24-120 / 6

GN 1/3 - 176 X 325 mm



REF.	H(mm)	e(mm)	LT	€	UE / MOQ
10179	20	0,7		7,19	1-6-18-0-0 / 6
10181	40	0,7		9,41	1-6-18-0-0 / 6
11905	55	0,7		10,86	1-6-18-0-0 / 6
10183	65	0,7	2,4	11,07	1-6-18-0-0 / 6
10185	100	0,7	3,5	14,02	1-6-18-0-0 / 6
10187	150	0,7	5,4	22,04	1-6-18-0-0 / 6
10188	200	0,7	7,2	31,59	1-0-6-0-0 / 6

GN 1/4 - 162 X 265 mm

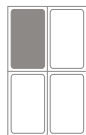

REF.	H(mm)	e(mm)	LT	€	UE / MOQ
10190	20	0,7		6,13	1-6-24-0-0 / 6
10432	40	0,7		7,65	1-6-24-0-0 / 6
10192	65	0,7	1,7	9,36	1-6-24-0-0 / 6
10194	100	0,7	2,5	12,50	1-6-24-0-0 / 6
10195	150	0,7	3,8	18,31	1-6-24-0-0 / 6
10196	200	0,7	4,8	29,13	1-6-24-0-0 / 6



GN 1/6 - 162 X 176 mm



REF.	H(mm)	e(mm)	LT	€	UE / MOQ
10197	65	0,7	1	7,15	1-6-36-0-0 / 6
10199	100	0,7	1,5	9,45	1-6-36-0-0 / 6
10200	150	0,7	2,3	13,28	1-6-36-0-0 / 6
10201	200	0,7	3,3	23,52	1-6-36-0-0 / 6



GN 1/9 - 108 X 176 mm



REF.	H(mm)	e(mm)	LT	€	UE / MOQ
10203	65	0,7	0,6	5,53	1-6-48-0-0 / 6
10205	100	0,7	0,8	8,25	1-6-48-0-0 / 6

GN 2/1 - 650 X 530 mm



REF.	H(mm)	e(mm)	LT	€	UE / MOQ
10141	20	0,8		43,49	1-0-6-24-120 / 6
10142	40	0,8		45,37	1-0-6-24-120 / 6
10143	65	0,8	8,8	47,86	1-0-6-24-120 / 6
10144	100	0,8	13,7	61,65	1-0-6-24-120 / 6
10145	150	0,8	20	92,24	1-0-6-24-120 / 6
10146	200	0,8	27,8	104,57	1-0-6-24-120 / 6

GN 2/4 - 162 X 530 mm

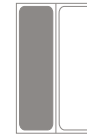

REF.	H(mm)	e(mm)	LT	€	UE / MOQ
10175	65	0,7	0,7	24,91	1-6-24-0-0 / 6
10176	100	0,7	0,7	33,11	1-6-24-0-0 / 6
10177	150	0,7	0,8	42,22	1-6-24-0-0 / 6

GN 2/3 - 325 X 353 mm



REF.	H(mm)	e(mm)	LT	€	UE / MOQ
10155	20	0,7	0,7	16,00	1-6-24-0-0 / 6
10157	40	0,7	0,7	16,93	1-6-24-0-0 / 6
10159	65	0,7	0,8	19,96	1-6-24-0-0 / 6
10160	100	0,7		26,83	1-6-24-0-0 / 6
10161	150	0,7		39,45	1-6-24-0-0 / 6
10162	200	0,7		54,18	1-6-24-0-0 / 6

Fondo perforado
Perforated bottom
Egouttoirs pour bacs
Falso fondo forato
Abtropfgitter



Perfil divisorio gastronómico
Adaptable bars
Barrettes de composition
Separatore
Adapter



REF.	W(mm)	L(mm)	e(mm)	FORMATO	€
10206	470	590	0,7	GN 2/1	53,28
10207	469	269	0,7	GN 1/1	20,75
10209	271	211	0,7	GN 1/2	20,52
10210	266	116	0,7	GN 1/3	18,65
10211	118	106	0,7	GN 1/6	12,64

REF.	FORMATO	e(mm)	€
10212	GN 1/1	0,7	7,14
10213	GN 1/2	0,7	4,49



Apto para horno.
Oven safe.

GN / Inox AISI 304 - 18/10
GN / Stainless Steel 304 - 18/10

GN 1/1 - Perforated - Perforé - Forate - Perforiert - 325 X 530 mm



REF.	H(mm)	e(mm)	LT	€	UE / MOQ
10220	20	0,7		20,66	1-0-6-24-120 / 6
10221	40	0,7		23,75	1-0-6-24-120 / 6
10222	55	0,7		32,12	1-0-6-24-120 / 6
10223	65	0,7	8,8	26,65	1-0-6-24-120 / 6
10224	100	0,7	13,7	32,32	1-0-6-24-120 / 6
10225	150	0,7	20	41,64	1-0-6-24-120 / 6
10226	200	0,7	27,8	57,31	1-0-6-24-120 / 6

GN 1/2 - Perforated - Perforé - Forate - Perforiert - 265 X 325 mm



REF.	H(mm)	e(mm)	LT	€	UE / MOQ
10234	65	0,7	8,8	16,42	1-0-6-24-120 / 6
10235	100	0,7	13,7	21,26	1-0-6-24-120 / 6
10236	150	0,7	20	27,57	1-0-6-24-120 / 6
10237	200	0,7	27,8	38,36	1-0-6-24-120 / 6

GN 1/3 - Perforated - Perforé - Forate - Perforiert - 176 X 325 mm

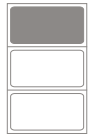

REF.	H(mm)	e(mm)	LT	€	UE / MOQ
10238	40	0,7		11,71	1-6-18-0-0 / 6
10239	65	0,7	2,4	13,37	1-6-18-0-0 / 6
10240	100	0,7	3,5	16,32	1-6-18-0-0 / 6
10241	150	0,7	5,4	24,35	1-6-18-0-0 / 6
10242	200	0,7	7,2	33,89	1-6-18-0-0 / 6

GN 2/1 - Perforated - Perforé - Forate - Perforiert - 650 X 530 mm



REF.	H(mm)	e(mm)	LT	€	UE / MOQ
10214	20	0,8		55,28	1-6-24-0-0 / 6
10215	40	0,8		57,19	1-6-24-0-0 / 6
10216	65	0,8	1,7	68,67	1-6-24-0-0 / 6
10217	100	0,8	2,5	86,51	1-6-24-0-0 / 6
10218	150	0,8	3,8	126,11	1-6-24-0-0 / 6
10219	200	0,8	4,8	143,96	1-6-24-0-0 / 6

GN 2/3 - Perforated - Perforé - Forate - Perforiert - 325 X 353 mm

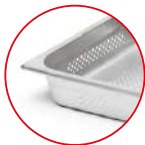

REF.	H(mm)	e(mm)	LT	€	UE / MOQ
10227	20	0,7		18,41	1-6-24-0-0 / 6
10228	40	0,7		21,73	1-6-24-0-0 / 6
10230	65	0,7	1,7	24,02	1-6-24-0-0 / 6
10231	100	0,7	2,5	34,30	1-6-24-0-0 / 6
10232	150	0,7	3,8	55,70	1-6-24-0-0 / 6
10233	200	0,7	4,8	65,35	1-6-24-0-0 / 6

Tapa GN

GN Lid - Couvercle GN - Coperchio GN - GN-deckel - 162 X 176 mm



REF.	GN	e(mm)	€	UE / MOQ
10243	1/1	0,7	17,71	1-0-6-0-0 / 6
11912	2/1	0,8	37,26	1-0-6-0-0 / 6
10245	2/3	0,7	18,26	1-0-6-0-0 / 6
10247	1/2	0,7	9,78	1-0-6-0-0 / 6
10249	1/3	0,7	7,61	1-0-6-0-0 / 6
10251	1/4	0,7	6,46	1-0-6-0-0 / 6
10253	1/6	0,7	4,43	1-0-6-0-0 / 6
10255	1/9	0,7	3,46	1-0-6-0-0 / 6

Tapa GN cierre hermético

GN hermetic lid - Couvercle étanche GN - Coperchio ermetico GN - GN-steck-deckel

NEW



REF.	GN	e(mm)	€	UE / MOQ
10258	1/1	0,7	35,69	1-0-6-0-0 / 6
10259	1/2	0,7	24,96	1-0-6-0-0 / 6
10260	1/3	0,7	21,37	1-0-6-0-0 / 6
10261	1/4	0,7	18,62	1-0-6-0-0 / 6
10262	1/6	0,7	14,54	1-0-6-0-0 / 6

Tapa GN orificio asas

GN lid with hole for handles - Couvercle GN avec trou pour poignées - Coperchio GN con foro per maniglie - GN-deckel Lock für Griffe

NEW



REF.	GN	e(mm)	€	UE / MOQ
10263	1/1	0,7	17,53	1-0-6-0-0 / 6
10265	1/2	0,7	10,04	1-6-12-0-0 / 6
10266	1/3	0,7	8,02	1-6-18-0-0 / 6
10267	1/4	0,7	6,96	1-6-24-0-0 / 6
10268	1/6	0,7	5,02	1-6-36-0-0 / 6

Tapa GN orificio cucharón

GN lid with ladle hole - Couvercle GN avec trou pour louche - Coperchio GN con foro mestolo - GN-deckel loch kelle 1/1

NEW



REF.	GN	e(mm)	€	UE / MOQ
10269	1/1	0,7	17,13	1-0-6-0-0 / 6
10270	1/2	0,7	9,65	1-6-12-0-0 / 6
10271	1/3	0,7	7,62	1-6-18-0-0 / 6
10272	1/4	0,7	6,52	1-6-24-0-0 / 6
10273	1/6	0,7	4,62	1-6-36-0-0 / 6

Tapa GN sin asa

GN flat lid without handle - Couvercle plat GN sans poignée - Coperchio piatto GN senza manico - GN-Flachdeckel ohne Griff

NEW



REF.	GN	e(mm)	€	UE / MOQ
10256	1/1	0,7	21,44	1-0-6-0-0 / 6
10257	1/2	0,7	12,38	1-0-6-0-0 / 6



Apto horno.
Oven save.



Apto lavavajillas.
Dishwasher save.



Apilable.
Stackable.



-20°C
300 °C



Apto contacto
alimentario.
Food contact save.

COMPATIBLE CON
LAS PRINCIPALES
MARCAS DEL
MERCADO
COMPATIBLE WITH ALL
MAJOR BRANDS ON THE
MARKET



USO
RECOMENDADO
EN BUFFET
RECOMMENDED
BUFFET USE



Medida estampada en la esquina

Measurement stamped on the corner



Esquinas reforzadas
reinforced corners



Apilable
Stackable



Modelo perforado perfecto para el
drenaje de líquidos y cocción al vapor.

Perforated model perfect for drain-
ing liquids and steaming.

GN 1/1 - 325 X 530 mm



REF.	H(mm)	e(mm)	LT	€	UE / MOQ
10566	20	0,7		11,68	1-0-6-24-264 / 6
10567	40	0,7		13,48	1-0-6-24-264 / 6
10568	55	0,7		16,68	1-0-6-24-192 / 6
10569	65	0,8	8,8	15,71	1-0-6-24-192 / 6
10839	65	0,7	8,8	11,50	1-0-6-24-120 / 6
10570	100	0,7	13,7	20,53	1-0-6-24-120 / 6
10571	150	0,7	20	30,80	1-0-6-24-120 / 6
10572	200	0,7	27,8	37,72	1-0-6-24-96 / 6

GN 1/2 - 265 X 325 mm



REF.	H(mm)	e(mm)	LT	€	UE / MOQ
10573	20	0,7		5,78	1-6-12-48-528 / 6
10574	40	0,7		7,96	1-6-12-48-528 / 6
10575	65	0,7	4	9,24	1-6-12-48-336 / 6
10576	100	0,7	6,1	12,58	1-6-12-48-240 / 6
10577	150	0,7	9,2	19,40	1-6-12-48-192 / 6
10578	200	0,7	12	23,49	1-6-12-48-144 / 6

GN 1/3 - 176 X 325 mm



REF.	H(mm)	e(mm)	LT	€	UE / MOQ
10579	20	0,7		4,84	1-6-18-72-360 / 6
10580	40	0,7		6,80	1-6-18-72-360 / 6
10581	65	0,7	2,4	7,06	1-6-18-72-26 / 6
10582	100	0,7	3,5	9,88	1-6-18-72-144 / 6
10583	150	0,7	5,4	13,48	1-6-18-72-144 / 6
10584	200	0,7	7,2	17,84	1-6-18-72-144 / 6

GN 1/4 - 162 X 265 mm



REF.	H(mm)	e(mm)	LT	€	UE / MOQ
10585	20	0,7		4,75	1-6-24-96-480 / 6
10586	40	0,7		6,53	1-6-24-96-480 / 6
10587	65	0,7	1,7	6,39	1-6-24-72-216 / 6
10588	100	0,7	2,5	8,54	1-6-24-96-192 / 6
10589	150	0,7	3,8	13,06	1-6-24-96-192 / 6
10590	200	0,7	4,8	15,52	1-6-24-96-96 / 6



Certificado
contacto
alimentario.



-20°C
300°C

GN 1/6 - 162 X 176 mm



REF.	H(mm)	e(mm)	LT	€	UE / MOQ
10591	65	0,7	1	4,71	1-6-36-0-0 / 6
10592	100	0,7	1,5	6,96	1-6-36-0-0 / 6
10593	150	0,7	2,3	10,28	1-6-36-0-0 / 6
10594	200	0,7	3,3	12,71	1-6-36-0-0 / 6

GN 1/9 - 108 X 176 mm



REF.	H(mm)	e(mm)	LT	€	UE / MOQ
10595	65	0,7	0,6	4,10	1-6-48-0-0 / 6
10596	100	0,7	0,8	6,17	1-6-48-0-0 / 6

GN 1/1 Perforada - Perforated - Perforé - Forate - Perforiert - 325 x 530 mm



REF.	H(mm)	e(mm)	€	UE / MOQ
10617	65	0,7	16,18	1-0-6-0-0 / 6
10618	100	0,7	21,64	1-0-6-0-0 / 6
10619	150	0,7	29,66	1-0-6-0-0 / 6
10620	200	0,7	33,43	1-0-6-0-0 / 6

GN 1/2 Perforada - Perforated - Perforé - Forate - Perforiert - 265 X 325 mm



REF.	H(mm)	e(mm)	€	UE / MOQ
10621	65	0,7	10,09	1-6-12-0-0 / 6
10622	100	0,7	13,39	1-6-12-0-0 / 6

Tapa GN inox
GN lid - Couverture GN - Coperchio GN - GN-deckel



INOX
STAINLESS
STEEL
201

REF.	GN	e(mm)	€	UE / MOQ
10630	1/1	0,7	10,91	1-0-6-0-0 / 6
10632	1/2	0,7	6,80	1-6-12-0-0 / 6
10633	1/3	0,7	5,13	1-6-18-0-0 / 6
10634	1/4	0,7	4,75	1-6-24-0-0 / 6
10635	1/6	0,7	2,95	1-6-36-0-0 / 6
10636	1/9	0,7	2,61	1-6-48-0-0 / 6

Tapa GN cierre hermético
GN hermetic lid - Couverture étanche GN - Coperchio ermetico GN - GN-steck-deckel

Válvula para facilitar la apertura.
Valve for easy opening.



INOX
STAINLESS
STEEL
201

REF.	GN	e(mm)	€	UE / MOQ
10637	1/1	0,7	36,40	1-0-6-0-0 / 6
10638	1/2	0,7	24,51	1-6-12-0-0 / 6
10639	1/3	0,7	21,43	1-6-18-0-0 / 6
10640	1/4	0,7	18,22	1-6-24-0-0 / 6
10641	1/6	0,7	14,89	1-6-36-0-0 / 6

INOX
STAINLESS
STEEL
201

Doble fondo perforado
Perforated bottom
Egouttoirs pour bacs
Falso fondo forato
Abtropfgitter



REF.	FORMATO	e(mm)	€	UE / MOQ
10612	GN 1/1	0,7	17,85	1-0-10-0-0 / 10

INOX
STAINLESS
STEEL
201

Perfil divisorio GN
Adaptable bars
Barrettes de composition
Separatore
Adapter



REF.	FORMATO	e(mm)	€	UE / MOQ
10614	GN 1/1	0,7	6,03	1-0-120-0-0 / 12
10615	GN 1/2	0,7	3,72	1-0-120-0-0 / 12

Rueda de untar inox
Stainless steel spread wheel
Roue tartiner en acier inoxydable
Ruota per spalmare in acciaio inossidabile
Butterrad aus Edelstahl



REF.	W(mm)	L(mm)	H(mm)	€
11602	160	175	125	35,38

Parrilla horno pastelera
Pastry oven grill 60x40
Gril au four pâtisserie 60x40
Griglia forno pasticceria 60x40
Backofengrill 60x40

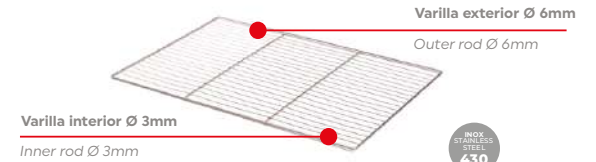

INOX
STAINLESS
STEEL
430

REF.	W(mm)	L(mm)	€	UE / MOQ
11014	600	400	21,41	1-6-12-0-0 / 6

Parrilla horno GN 1/1
Oven grill gn 1/1
Gril au four gn 1/1
Griglia forno gn 1/1
Backofengrill gn 1/1

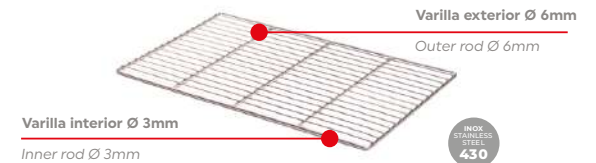

INOX
STAINLESS
STEEL
430

REF.	W(mm)	L(mm)	€	UE / MOQ
11015	325	530	19,12	1-6-12-0-0 / 6



NEW

Carro Servicio
Serving Trolley
Chariot Service
Carrello Da Servizio
Servierwagen

INOX
STAINLESS
STEEL
201

REF.	LEVELS	W(mm)	L(mm)	H(mm)	€	UE / MOQ
11774	2	860	540	940	158,68	0-0-1-0-0 / 1
11775	3	860	540	940	187,48	0-0-1-0-0 / 1

NEW

Carro Racks Alto
Rack Trolley High
Chariot À Rack Élevé
Carrello Rack Alto
Hoher Tablettwagen Für



INOX
STAINLESS
STEEL
201

REF.	LEVELS	W(mm)	L(mm)	H(mm)	€	UE / MOQ
11773	7	510	1700	560	221,53	0-0-1-0-0 / 1



NEW



Ruedas pivotantes con freno en 2 de ellas.
Swivel castors with brakes on 2 of them.

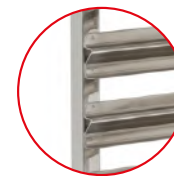

Guía en "S", que permite una doble posición de las bandejas y mayor optimización del espacio.
S' guide, which allows double positioning of the trays and greater optimisation of space.



Varilla de seguridad bilateral para bloquear las bandejas.
Safety rod on the side to lock the trays.



GN 1/1

18 NIVELES
18 LEVELS



GN 1/1

9 NIVELES
9 LEVELS



GN 2/1

18 NIVELES
18 LEVELS



60x40 CM

18 NIVELES
18 LEVELS

● **Ligeros. Fabricados en acero inoxidable AISI 201.**
Lightweight. Made of AISI 201 stainless steel.

● **Resistentes. Soportan hasta 150 kg.**
Resistant. Supports up to 150 kg.

● **Fácil montaje.**
Easy assembly.

Carro Portabandejas Gn
Gn Container Trolley
Chariot Porte-Plateaux Gn
Carrello Portavassoi Gn
Gn-Tablett-/Regalwagen

INOX
STAINLESS
STEEL
201

REF.	SIZE	LAYERS	W(mm)	L(mm)	H(mm)	€	UE / MOQ
11769	GN 1/1	18	380	550	1735	266,80	0-0-1-0-0 / 1
11956	GN 1/1	9	380	550	1000	243,55	0-0-1-0-0 / 1
11770	GN 2/1	18	590	670	1735	446,58	0-0-1-0-0 / 1
11771	60x40	18	470	620	1735	308,91	0-0-1-0-0 / 1

LOGÍSTICA

LOGISTICS



336 RACKS

- 336 CESTAS Y EXTENDERS
- 338 MONTADOS
- 340 COMPLEMENTOS

342 CONTENEDORES ISOTÉRMICOS

THERMOBOX

- 344 CARGADOR FRONTAL
- 347 CONTENEDORES



Racks industriales robustos para lavar, almacenar y transportar cualquier tipo de plato, vaso, copa, cubertería, etc.

El borde superior y la forma de los fondos están hechos para apilarlos de forma fácil y firme.

Los extensores permiten alcanzar la altura ideal para el almacenamiento y lavado.

Robust industrial racks for washing, storing and transporting any type of plate, glass, cup, glassware, cutlery, etc.

The top edge and the shape of the bottoms are made for easy and firm stacking.

The extenders allow to reach the ideal height for storage and washing.

Fabricado en PP de alta calidad, apto para contacto alimentario, el mejor material contra productos químicos y altas temperaturas (hasta 100°C)

Made of high quality PP, suitable for food contact, the best material against chemicals and high temperatures (up to 100°C)

Rejillas abiertas para un perfecto lavado y secado

Open grids for perfect washing and drying

Las asas y las esquinas redondeadas, lo hacen seguro y fácil de manejar

Easily to handle four sides.

El borde superior y la forma de los fondos están hechos para apilarlos de forma fácil y firme

The top edge and the shape of the bottoms are made for easy and firm stacking



Cesta de lavado universal

Universal rack
Universal rack
Rack universale
Universal rack



REF.	MEDIDA EXTERNA W(mm) L(mm)		MEDIDA INTERNA W(mm) L(mm)		€	UE / MOQ
11039	500	500	476	476	23,78	1-0-6-0-0 / 6

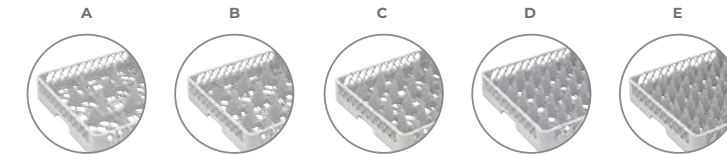

Cesta de lavado compartimento / Rack compartiment / Rack compartiment / Rack scomparto / Rack fächer

REF.	MEDIDA EXTERNA W(mm) L(mm)		MEDIDA INTERNA W(mm) L(mm)		COMPARTIMENTOS	€	UE / MOQ
A 11040	500	500	151	151	9	25,48	1-0-6-0-0 / 6
B 11041	500	500	115	115	16	28,02	1-0-6-0-0 / 6
C 11042	500	500	88	88	25	29,72	1-0-6-0-0 / 6
D 11043	500	500	73	73	36	31,84	1-0-6-0-0 / 6
E 11044	500	500	62	62	49	33,97	1-0-6-0-0 / 6

Extender universal

Universal extender
Universal extender
Extender universale
Universal extender



REF.	MEDIDA EXTERNA W(mm) L(mm)		MEDIDA INTERNA W(mm) L(mm)		€	UE / MOQ
11048	500	500	476	476	10,61	1-0-12-0-0 / 12

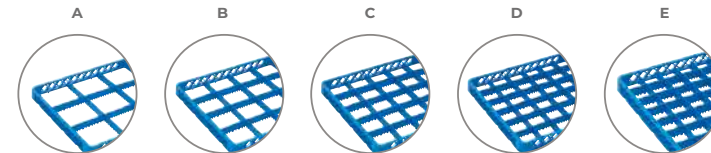

Extender compartimentos / Extender compartiment / Extender compartimen / Extender scomparto / Extender fächer

REF.	MEDIDA EXTERNA W(mm) L(mm)		MEDIDA INTERNA W(mm) L(mm)		COMPARTIMENTOS	€	UE / MOQ
A 11049	500	500	151	151	9	11,89	1-0-12-0-0 / 12
B 11050	500	500	115	115	16	11,89	1-0-12-0-0 / 12
C 11051	500	500	88	88	25	12,74	1-0-12-0-0 / 12
D 11052	500	500	73	73	36	12,74	1-0-12-0-0 / 12
E 11053	500	500	62	62	49	13,59	1-0-12-0-0 / 12



Racks.

GUÍA DE MEDIDAS / GUIDE TO MEASURE

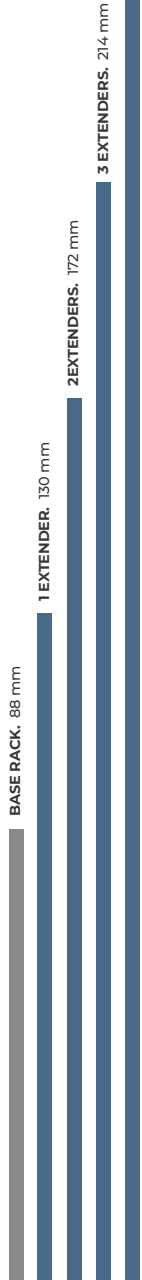

- Monta tu propia altura según tus necesidades.
Set your own height according to your needs.
- Fácil sistema de montaje y que permite adaptar los racks a tus productos.
Easy assembly system that allows you to adapt the racks to your products.
- Se pueden añadir tantos suplementos como se desee.
You can add as many supplements as you wish.
- Una vez montados no se pueden desmontar.
Once assembled, they cannot be disassembled.

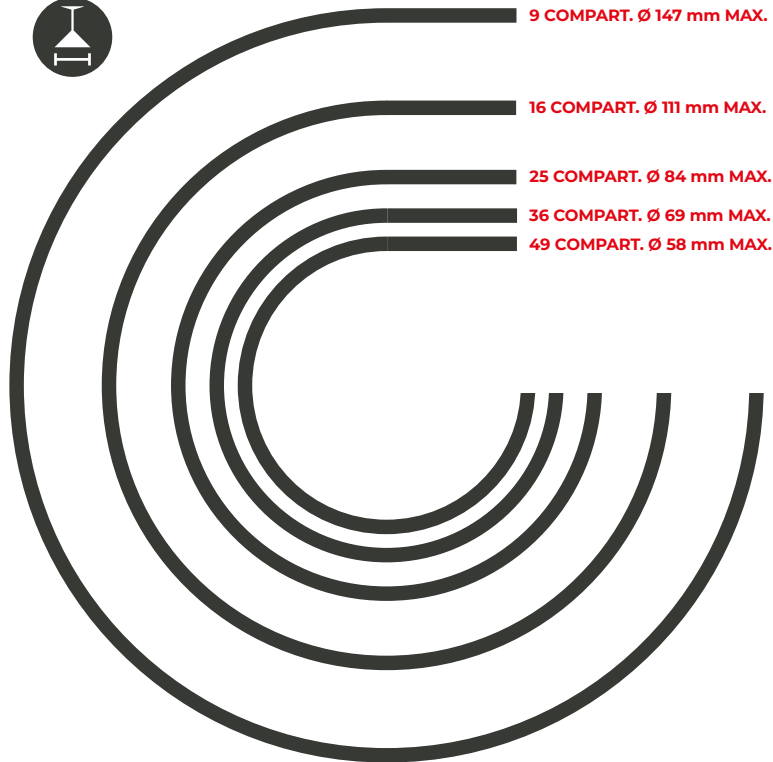

338



**PACK cestas de lavado
9 compartimentos**
PACK rack 9 compartment
PACK rack 9 scomparto
PACK rack 9 fächer



REF.	EXTENDER	ALTURA	€	UE / MOQ
11145	+1	130	37,35	1-0-6-0-0 / 6
11146	+2	172	49,24	1-0-6-0-0 / 6
11147	+3	214	61,13	1-0-6-0-0 / 6
11148	+4	256	73,01	1-0-6-0-0 / 6
11149	+5	298	84,90	1-0-6-0-0 / 6



**PACK cestas de lavado
25 compartimentos**
PACK rack 25 compartment
PACK rack 25 scomparto
PACK rack 25 fächer



REF.	EXTENDER	ALTURA	€	UE / MOQ
11155	+1	130	42,47	1-0-6-0-0 / 6
11156	+2	172	55,21	1-0-6-0-0 / 6
11157	+3	214	67,95	1-0-6-0-0 / 6
11158	+4	256	80,70	1-0-6-0-0 / 6
11159	+5	298	93,44	1-0-6-0-0 / 6



**PACK cestas de lavado
49 compartimentos**
PACK rack 49 compartment
PACK rack 49 scomparto
PACK rack 49 fächer



REF.	EXTENDER	ALTURA	€	UE / MOQ
11165	+1	130	47,55	1-0-6-0-0 / 6
11166	+2	172	61,14	1-0-6-0-0 / 6
11167	+3	214	74,72	1-0-6-0-0 / 6
11168	+4	256	88,30	1-0-6-0-0 / 6
11169	+5	298	101,88	1-0-6-0-0 / 6

Montados abiertos Open assembled



**PACK cestas de lavado
16 compartimentos**
PACK rack 16 compartment
PACK rack 16 scomparto
PACK rack 16 fächer



REF.	EXTENDER	ALTURA	€	UE / MOQ
11150	+1	130	39,90	1-0-6-0-0 / 6
11151	+2	172	51,79	1-0-6-0-0 / 6
11152	+3	214	63,68	1-0-6-0-0 / 6
11153	+4	256	75,56	1-0-6-0-0 / 6
11154	+5	298	87,45	1-0-6-0-0 / 6



**PACK cestas de lavado
36 compartimentos**
PACK rack 36 compartment
PACK rack 36 scomparto
PACK rack 36 fächer



REF.	EXTENDER	ALTURA	€	UE / MOQ
11160	+1	130	44,59	1-0-6-0-0 / 6
11161	+2	172	57,34	1-0-6-0-0 / 6
11162	+3	214	70,08	1-0-6-0-0 / 6
11163	+4	256	82,82	1-0-6-0-0 / 6
11164	+5	298	95,56	1-0-6-0-0 / 6

Pack 10 clips para cestas
Pack 10 rack clip
Pack 10 rack clip
Pack 10 rack clip
Pack 10 rack clip



REF.	COLOR	W(mm)	L(mm)	€	UE / MOQ
11059	○	20	0,7	9,87	1-0-100-0-0 / 100
11060	●	20	0,7	9,87	1-0-100-0-0 / 100
11061	●	20	0,7	9,87	1-0-100-0-0 / 100
11062	●	20	0,7	9,87	1-0-100-0-0 / 100
11063	●	20	0,7	9,87	1-0-100-0-0 / 100
11064	●	20	0,7	9,87	1-0-100-0-0 / 100
11065	●	20	0,7	9,87	1-0-100-0-0 / 100

339



Cesta de lavado para cubertería
Rack for cutlery
Rack pour les couverts
Rack per posate
Rack für besteck



REF.	W(mm)	L(mm)	€	UE / MOQ
11045	500	500	23,33	1-0-6-0-0 / 6

Cesta de lavado para bandejas
Rack for trays
Rack pour plateaux
Rack per vassoio
Rack für tablett



REF.	W(mm)	L(mm)	€	UE / MOQ
11046	500	500	23,78	1-0-6-0-0 / 6

Cesta de lavado para vajilla
Rack for plates
Rack pour les plats
Rack per piatti
Rack für teller



REF.	W(mm)	L(mm)	€	UE / MOQ
11047	500	500	23,78	1-0-6-0-0 / 6

Tapa para cesta de lavado
Rack couvercle
Rack coperschio
Rack deckel



REF.	W(mm)	L(mm)	€	UE / MOQ
11076	500	500	18,40	1-0-12-0-0 / 12

Cesta para cubertería
Rack for cutlery
Rack pour les couverts
Rack per posate
Rack für besteck



REF.	W(mm)	L(mm)	COMPARTIMENTOS	€	UE / MOQ
11055			1	5,26	1-0-150-0-0 / 150
11054	430	205	8	15,29	1-0-10-0-0 / 10

Asa para cesta cubertería
Handle for rack for cutlery
Poignée pour rack pour les couverts
Manico per rack per posate
Griff für rack für besteck



REF.	W(mm)	L(mm)	€	UE / MOQ
11079	500	500	2,98	1-0-10-0-0 / 10

Carro para cesta de lavado sin asa
Rack trolley without handle
Rack chariot sans poignée
Rack carrello senza maniglia
Rack wagen ohne griff



REF.	W(mm)	L(mm)	€	UE / MOQ
11077	500	500	122,33	1-0-1-0-0 / 1

Carro para cesta de lavado con asa
Rack trolley with handle
Rack chariot avec poignée
Rack carrello con maniglia
Rack wagen mit griff



REF.	W(mm)	L(mm)	€	UE / MOQ
11078	500	500	188,74	1-0-1-0-0 / 1



INOX
STAINLESS
STEEL
201

Carro Racks Alto
Rack Trolley High
Chariot À Rack Élevé
Carrello Rack Alto
Hoher Tablettwagen Für



REF.	CAPACIDAD	W(mm)	L(mm)	H(mm)	€	UE / MOQ
11773	7	560	510	1735	221,53	1-0-6-0-0 / 6

Especial para lavavajillas de barra.
Specially for countertop dishwashers

Rack 35,5 x 35,5
Rack
Rack
Rack
Rack



REF.	W(mm)	L(mm)	H(mm)	€	UE / MOQ
11616	355	355	150	20,06	1-0-6-0-0 / 6

Rack 40 x 40
Rack
Rack
Rack
Rack



REF.	W(mm)	L(mm)	H(mm)	€	UE / MOQ
11617	400	400	150	21,70	1-0-6-0-0 / 6



Empresa alemana fundada en 2001. Líder del mercado europeo con más de 100 cajas de EPP diferentes para el transporte de productos frescos, calientes o fríos.

German company founded in 2001. European market leader with more than 100 different EPP boxes for the transport of fresh, hot or cold products.



Conoce THERMOBOX y condiciones de venta en la página: 520
More about THERMOBOX and sales conditions in page: 520

Asa resistente para transportarla con una sola mano.

Sturdy handle for carrying with one hand.

Caja térmica adecuada que encaja perfectamente y es fácil de usar.

Proper cool box that fits perfectly and is easy to use.

Tapa hermética fácil de abrir y cerrar.

Airtight lid easy to open and close.

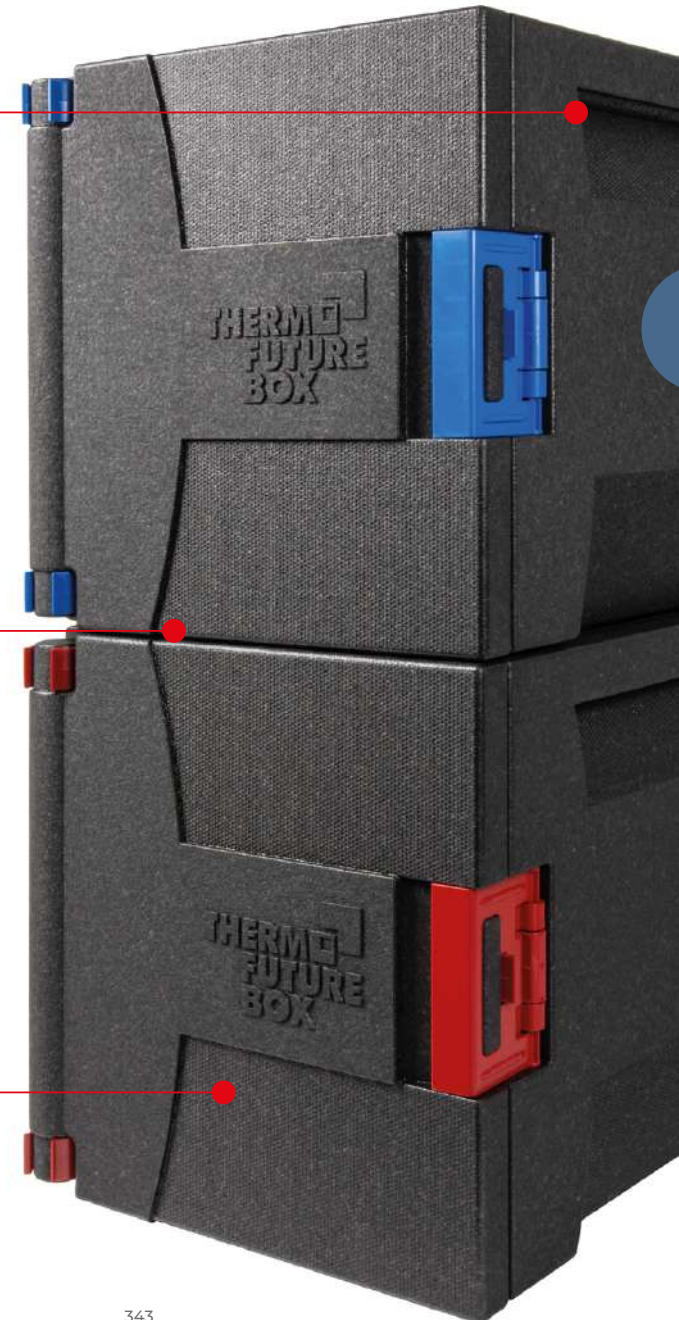



GN / Cargador frontal
GN / Frontloader

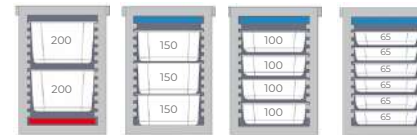

Contenedor isotérmico carga frontal GN 93-12
Thermobox frontloader GN 93-12
Conteneur isotherme à ouverture frontale GN 93-12
Contentore isothermico per carico frontale GN 93-12
Thermobox frontlader GN 93-12

REF.	COLOR	OUTSIDE			INSIDE			CARRILES(mm)	V(litros)	€
		W(mm)	L(mm)	H(mm)	W(mm)	L(mm)	H(mm)			
10416	●	440	645	625	335	530	525	12 - 32	93	403,07

Set Rueda + Base
Wheels + Base Set
Kit Roue + Base
Set Ruota+ Base
Set Rad + Base



REF.	W(mm)	L(mm)	H(mm)	€
11762	400	600	180	179,06



Contenedor isotérmico carga frontal GN 69-9
Thermobox frontloader GN 69-9
Conteneur isotherme à ouverture frontal GN 69-9
Contenitore isothermico per carico frontale GN 69-9
Thermobox frontlader GN 69-9

REF.	COLOR	OUTSIDE			INSIDE			CARRILES(mm)	V(litros)	€
		W(mm)	L(mm)	H(mm)	W(mm)	L(mm)	H(mm)			
10417	●	450	660	490	335	530	390	9 - 38	69	240,21

Set Rueda + Base
Wheels + Base Set
Kit Roue + Base
Set Ruota+ Base
Set Rad + Base

REF.	W(mm)	L(mm)	H(mm)	€
11763	400	600	180	194,78



GN
SIZE

Contenedor isotérmico GN 1/1 PREMIUM
Thermobox GN 1/1 PREMIUM
Conteneur isotherme GN 1/1 PREMIUM
Contenitore isothermico GN 1/1 PREMIUM
Thermobox GN 1/1 PREMIUM

REF.	W(mm)	OUTSIDE L(mm)	H(mm)	INSIDE W(mm)	L(mm)	H(mm)	V(litros)	€
10409	400	600	180	337	538	117	21	70,90
10410	400	600	230	337	538	167	30	73,78
10411	400	600	280	337	538	217	39	77,29
10412	400	600	320	337	538	257	46	80,89
10413	400	600	400	337	538	337	61	107,07



Cooling Top Gn 1/1 Premium
Cooling Top Gn 1/1 Premium
Plaque Réfrigérante Gn 1/1 Premium
Piano Di Raffreddamento Gn 1/1 Premium
Gn-Kühlauflsatz 1/1 Premium

REF.	W(mm)	L(mm)	H(mm)	€
11764	400	600	180	57,12



GN
SIZE

Contenedor isotérmico GN 1/1 DELUXE
Thermobox GN 1/1 DELUXE
Conteneur isotherme GN 1/1 DELUXE
Contenitore isothermico GN 1/1 DELUXE
Thermobox GN 1/1 DELUXE

REF.	W(mm)	OUTSIDE L(mm)	H(mm)	INSIDE W(mm)	L(mm)	H(mm)	V(litros)	€
10414	400	675	290	325	535	215	37	116,08
10415	400	675	335	325	535	260	45	109,73



Cooling Top Gn 1/1 Deluxe
Cooling Top Gn 1/1 Deluxe
Plaque Réfrigérante Gn 1/1 Deluxe
Piano Di Raffreddamento Gn 1/1 Deluxe
Gn-Kühlauflsatz 1/1 Deluxe

REF.	W(mm)	L(mm)	H(mm)	€
11765	400	600	180	71,09



Placa de calor
Hot Pack
Plaque chauffante
Piastra riscaldante
Wärme-akku

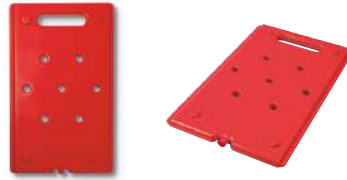

REF.	W(mm)	L(mm)	H(mm)	FORMATO	€
10423	325	530	25	GN 1/1	161,06

Calentamiento en el horno (max. 30min a 85°C) y baño maría (max. 30min).
Heating in the oven (max. 30min at 85°C), microwave and bain-marie (max. 30min).

Placa de frío
Cold pack
Plaque eutectique
Piastra eutetica
Kühl-akku



REF.	W(mm)	L(mm)	H(mm)	FORMATO	€
10424	325	530	25	GN 1/1	105,27

Refrigeración en el congelador (max. -12°C).
Cooling in the freezer (max. -12°C).



Contenedor isotérmico SHOPPING
Thermobox SHOPPING
Conteneur isotherme SHOPPING
Contentitore isotermico SHOPPING
Thermobox SHOPPING

REF.	COLOR	W(mm)	OUTSIDE L(mm)	H(mm)	W(mm)	INSIDE L(mm)	H(mm)	FORMATO	V(litros)	€
10420	●	285	360	365	220	300	310	GN 1/4	20	71,53



Caja para las mejores soluciones logísticas. Tamaño de embalaje optimizado, apilable con los contenedores más comunes, adecuado para contenedores de tamaño GN.

Box for best logistical solutions! Optimized packaging size, stackable with most common stacking containers, suitable for GN size containers.

GN
SIZE

Contenedor isotérmico BOXER
Thermobox BOXER
Conteneur isotherme BOXER
Contentitore isotermico BOXER
Thermobox BOXER



REF.	W(mm)	OUTSIDE L(mm)	H(mm)	W(mm)	INSIDE L(mm)	H(mm)	V(litros)	€
10422	395	595	290	340	540	230	42	56,80

Tamaño cuadrado optimizado. Con asas empotradas y tapa hermética.
Para recipientes GN 2/3, pizza o pasteles.

Optimized square size. With recessed grips, tight fitting lid.
For containers GN 2/3, pizza or cakes.

GN
SIZE

Contenedor isotérmico pizza BOXER
Thermobox pizza BOXER
Conteneur isotherme pizza BOXER
Contentitore isotermico pizza BOXER
Thermobox pizza BOXER



REF.	W(mm)	OUTSIDE L(mm)	H(mm)	W(mm)	INSIDE L(mm)	H(mm)	V(litros)	€
10421	400	415	265	350	365	210	27	55,98

Contenedor isotérmico ALLROUND 60/40
Thermobox ALLROUND 60/40
Conteneur isotherme ALLROUND 60/40
Contentitore isotermico ALLROUND 60/40
Thermobox ALLROUND 60/40



REF.	W(mm)	OUTSIDE L(mm)	H(mm)	W(mm)	INSIDE L(mm)	H(mm)	V(litros)	€
10418	485	660	260	425	625	200	53	98,08
10419	485	685	360	425	625	300	80	123,28

Logística / Logistic



- Base llana y robusta de 350 x 350 mm sin bordes.
Sturdy, flat base 350 x 350 mm without edges.
- Cierre seguro.
Secure locking.
- Superficie antideslizante.
Non-slip surface.



- Apilable con otros contenedores.
Stackable with other containers.
- Sistema de bloqueo en la base.
Locking system at the base.



Cake Box
Cake Box
Boîte À Gâteau
Scatola Per Torta
Kuchenvitrine

REF.	OUTSIDE			INSIDE			V (litros)	€
	W (mm)	L (mm)	H (mm)	W (mm)	L (mm)	H (mm)		
11766	400	415	280	350	350	175	21	71,09



Extender Cake Box
Extender Cake Box
Extension Boîte À Gâteau Noir
Estensore Per Scatola Torta
Erweiterung Kuchenvitrine

REF.	OUTSIDE			INSIDE			V (litros)	€
	W (mm)	L (mm)	H (mm)	W (mm)	L (mm)	H (mm)		
11767	410	410	135	350	350	120		44,54



Contenedor Isotérmico
Thermobox

