



**S SANTOS®**

Internationally patented brands and models  
Marques et modèles déposés France et International



*French*  
**MANUFACTURER  
OF FOOD, COFFEE, BAR  
& JUICE EQUIPMENT**

---

Fabricant français de matériel  
professionnel pour bars à jus,  
coffee shops, bars et restaurants



**2020 | 2021**

# SANTOS, 65 YEARS OF HISTORY

SANTOS, 65 ANS D'HISTOIRE

<b>Who are we?</b> Qui sommes-nous ?	<b>04</b>
<hr/>	
<b>JUICE SOLUTION</b> SOLUTIONS POUR LES JUS	<b>06</b>
<b>Citrus juicers</b> Presse-agrumes	<b>08</b>
<b>Juice extractors and Cold press juicer</b> Centrifugeuses et Extracteur de jus	<b>10</b>
<b>Our main accessories</b> Nos accessoires principaux	<b>12</b>
<hr/>	
<b>BAR EQUIPMENT</b> ÉQUIPEMENTS DE BAR	<b>14</b>
<b>Blenders and Drink dispenser</b> Blenders et Distributeur de boissons	<b>16</b>
<b>Ice crushers</b> Broyeurs à glaçons	<b>18</b>
<b>Our main accessories</b> Nos accessoires principaux	<b>19</b>

<b>SNACKING SOLUTION</b> SOLUTIONS POUR LE SNACKING	<b>20</b>
<b>Blender and Grater</b> Blender et Râpe	<b>22</b>
<b>Vegetable Cutter, Dough mixers, and Meat mincer</b> Coupe-légumes, Pétrin, Batteur, et Hachoir à viande	<b>23</b>
<b>Our main accessories</b> Nos accessoires principaux	<b>24</b>
<hr/>	
<b>COFFEE SHOP EQUIPMENT</b> ÉQUIPEMENTS POUR COFFEE SHOPS	<b>26</b>
<b>Espresso coffee grinders</b> Moulins à café expresso	<b>28</b>
<b>Coffee shop grinders</b> Moulins à café boutique	<b>30</b>
<b>Our main accessories</b> Nos accessoires principaux	<b>32</b>
<hr/>	
<b>Technical data</b> Données techniques	<b>34</b>

GAMME JUS  
*Juice range*



GAMME BAR  
*Bar range*



GAMME CUISINE  
*Food range*



GAMME CAFÉ  
*Coffee range*

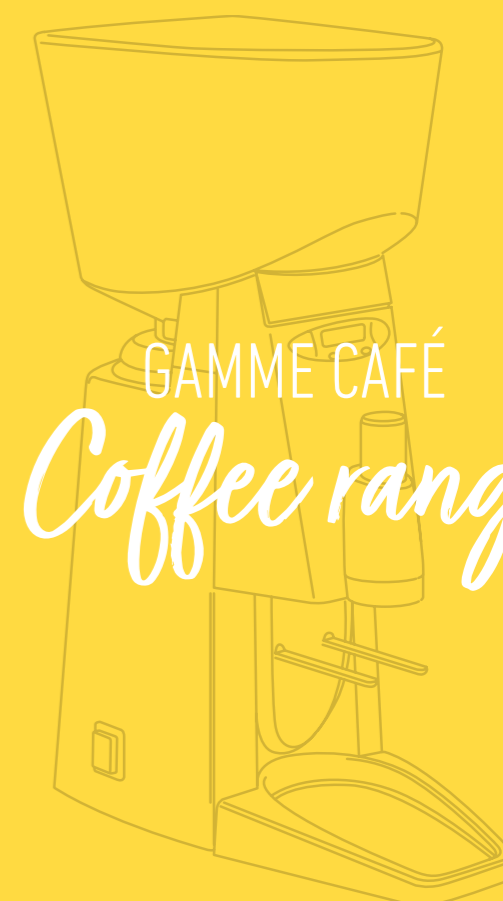



## 65 YEARS OF HISTORY

Santos, French manufacturer of food, coffee and juice equipment was created in 1954, by André Fouquet.

Originally, the company was providing professional coffee grinders and cheese graters to small retailers. 65 years after the launch of its first products, Santos continues to grow and the R&D department develops new and innovative products based on our savoir-faire with respect to production of motors. This is one of the reasons why Santos products are reputed for their robustness and reliability.

## 65 ANS D'HISTOIRE

Santos, fabricant français de matériel électrique pour la préparation culinaire, le café et les boissons fraîches, a été créé en 1954, par André Fouquet.

À l'origine, l'entreprise produisait des moulins à café et des râpes à fromage professionnels pour les épiceries de quartier. 65 ans après le lancement de ses premiers produits, Santos poursuit son développement en concevant des produits innovants basés sur son savoir-faire en matière de production et de bobinage des moteurs. C'est certainement l'une des raisons pour laquelle la marque Santos est réputée fiable et robuste.



# Innovation Quality

## WORLDWIDE NETWORK AND EXPERIENCE

Santos is now represented in more than 130 countries thanks to its network of resellers and importers who contribute to the success of our brand and products on their markets.

We participate in the most important tradeshows all over the world and develop our products to answer the needs of professionals in Europe, Asia, the Middle East, USA...

## UNE EXPÉRIENCE ET UN RÉSEAU AU NIVEAU MONDIAL

Notre réseau international de revendeurs et d'importateurs représente avec succès la marque et les produits Santos dans plus de 130 pays.

Nous participons aux principaux salons professionnels dans le monde entier et nous développons nos produits pour répondre aux besoins de nos clients en Europe, en Asie, au Moyen Orient, aux Etats-Unis...

## QUALITY, STANDARDS, SERVICE

The thousands of high quality appliances that are produced in our factory are in accordance with the most stringent international regulations (UL, GS, CE, NSF, KC, etc...) and can be adapted to all relevant voltages. Besides developing high quality products, our goal is to provide the best commercial and after-sales services. We know that your satisfaction depends on our efficiency.

## QUALITÉ, NORMES, SERVICE

Les milliers d'appareils qui sont fabriqués dans notre atelier respectent les normes internationales les plus strictes (UL, GS, CE, NSF, KC, etc...) et peuvent être adaptés à tous les voltages locaux.

Notre objectif est de vous fournir un service de qualité en complément de notre gamme de produits. Nous savons que votre satisfaction dépend de notre efficacité.



## MADE IN FRANCE

Offering high quality products 100% made in France has always been a priority for Santos. Since 1954, all our machines are designed and manufactured in our factory in Lyon, and our network of suppliers is local.

Santos appliances are hand-made by operators that are responsible for the appliance from the beginning of the production to the final control (100% tested after assembly).

Our solid international experience allows us to be very flexible, we always keep a maximum of items in stock, and we are able to meet tight deadlines.

## FABRICATION FRANÇAISE

Santos a toujours accordé une grande importance à la fabrication 100% française de ses appareils.

Depuis le début de l'aventure, en 1954, les produits Santos sont développés et fabriqués dans notre atelier, à Lyon, et notre réseau de fournisseurs est local.

Tous les produits sont montés par des opérateurs qui sont responsables des appareils du début de leur production jusqu'au contrôle final (100% testés en fin de fabrication).

Notre solide expérience internationale nous permet d'être très flexibles et nous sommes en mesure de garantir des délais courts avec un stock complet et diversifié.

# Service expertise



## INNOVATION, DESIGN AND ECO-CONCEPTION

Year after year, we develop innovative appliances that are the result of our market experience since 1954.

We focus more and more on developing eco-friendly products, integrating innovative technologies, to meet the needs of our customers: first company to launch a brushless motor in a blender which offers increased longevity and lower power consumption, food-zone materials without bisphenol A, packaging in moulded cellulose...

Our numerous awards attest to the innovative character of our products: Host Smart Label, Grand Prix Sirha Innovation, Snacking d'Or, Gulfhost Innovation Awards, Trophée Valo Resto Pro®...

In an eco-friendly approach, we use recyclable materials, such as stainless steel and aluminum, in order to combine robustness and respect for the environment.

Also, our appliances are built to last thanks to their design and the quality of their materials. We guarantee the availability of all spare parts for more than 10 years after the production of our appliances, so that they are durable and endlessly repairable.



# + Green technology

## INNOVATION, DESIGN ET ÉCO-CONCEPTION

Années après années, nous développons des appareils innovants qui sont le fruit de notre expérience du marché depuis 1954.

Nous attachons toujours plus d'importance au développement de produits respectueux de l'environnement, intégrant des technologies innovantes, pour répondre aux besoins de nos clients : première entreprise à développer un moteur brushless dans un blender offrant une longévité accrue et une consommation électrique plus faible, matériaux en zone alimentaire sans bisphénol A, emballages en cellulose moulée...

Nous avons reçu de nombreux prix, témoignant du caractère innovant de nos produits : Host Smart Label, Grand Prix Sirha Innovation, Snacking d'Or, Gulfhost Innovation Awards, Trophée Valo Resto Pro®...

Dans une démarche eco-responsable, nous utilisons des matériaux recyclables, tels que l'acier inoxydable et l'aluminium, afin d'allier robustesse et respect de l'environnement.

De plus, par leur conception et la qualité des matériaux utilisés, nos appareils sont conçus pour durer. Nous garantissons la disponibilité de toutes les pièces détachées plus de 10 ans après la fabrication de nos appareils, pour qu'ils soient durables et réparables à l'infini.



# Juice solutions

## Solutions pour les jus

Santos is the juicing equipment specialist since 1954 and provides a wide range of juicers for all needs!

Santos est le spécialiste de l'extraction de jus depuis 1954 et propose une large gamme d'équipements pour répondre à tous les besoins !



**68**

### Juice extractor *Miracle Edition*

Extract juice from various fruits and vegetables (like apples, carrots, pineapples...)

### La centrifugeuse *Miracle Édition*

Faites du jus de tous types de fruits et légumes (ex. pommes, carottes, ananas...)

**70**

### Citrus juicer *Evolution*

Make fresh orange, grapefruit or lemon juice

### Presse-agrumes à levier *évolution*

Réalisez des jus d'oranges, de pamplemousses ou de citrons

**65**

### Cold Press Juicer

Prepare fresh cold pressed juices from fruits, veggies, and leafy greens

### Extracteur de jus

Préparez des jus pressés à froid à base de fruits, légumes et herbes

# Healthy and Fresh

# A wide range of citrus juicers

UNE LARGE GAMME DE PRESSE-AGRUMES



**11**



30l/h



11 Green Vert



11 G Grey Gris



11 C Chrome Chromé

Since 1954  
Depuis 1954



**The genuine citrus juicer**

Classic citrus juicer (3 squeezers + cover)  
Painted base 11-11G or chromed base 11C

**L'authentique presse-agrumes professionnel**  
Presse-agrumes Classic (3 ogives + couvercle)  
Socle peint 11-11G ou socle chromé 11C

**10C**



30l/h



10 Grey Gris



10C Chrome Chromé



**Automatic citrus juicer with lever (1 squeezer)**

Painted 10 or chromed 10C

**Presse-agrumes à levier (1 ogive)**

Cuve et socle peints 10 ou chromés 10C

**70**



50l/h



70 Grey Gris



- Easy to clean
- Accepts all kinds of glasses and jugs
- Squeezer adapted to all kinds of citrus

- Facile à nettoyer
- Accepte tous types de verres et pichets
- Ogive adaptée à tous les agrumes

**Lever juicer Evolution 70 (1 squeezer)**

Painted (70)

**Presse-agrumes à levier 70 Evolution (1 ogive)**

Cuve et socle peints (70)

**71C**



15l/h



71C Grey Gris



**Mefra citrus juicer (1 squeezer)**

Grey base 71C

**Presse-agrumes Mefra (1 ogive)**

Socle gris 71C

**38G**



30l/h



38 Green Vert



38G Grey Gris



38C Chrome Chromé



**Citrus juicer (3 squeezers + cover)**

Painted base 38-38G or chromed base 38C

**Presse-agrumes (3 ogives + couvercle)**

Socle peint 38-38G ou socle chromé 38C

**52C**



40l/h



52G Grey Gris



52C Chrome Chromé



**High output Citrus juicer (3 squeezers)**

Painted base 52G or chromed base 52C

Accepts all kinds of glasses and jugs

**Presse-agrumes gros débit (3 ogives)**

Socle peint 52G ou socle chromé 52C

Accepte tous types de verres et pichets

**32T**

**32 BAC**



100l/h



32 T Stainless steel Inox



**Automatic orange juicer / stainless steel table 32T**

**Automatic orange juicer without table 32 Bac**

High output: 100l/h

Accepts all oranges from ø 60 to 90mm

**Presse-oranges automatique table inox 32T**

**Presse-oranges automatique sans table 32 Bac**

Grand débit : 100 l/h

Accepte toutes les oranges de ø 60 à 90 mm



We have the  
juice extractor  
you need

NOUS AVONS  
LA CENTRIFUGEUSE  
QU'IL VOUS FAUT



**28**



**28**  
Stainless steel  
Inox

**Centrifugal juice extractor**  
Perfect filtration  
**Centrifugeuse**  
Filtration parfaite

**68**



**68**  
Stainless steel  
Inox

**New generation centrifugal juice extractor Miracle Edition**  
Perfect filtration + wide feeding chute  
**Centrifugeuse nouvelle génération Miracle Édition**  
Filtration parfaite + large introduction

**68J**  
Juice bar version: delivered with pulp tube  
**Version bar à jus:**  
livrée avec un tube d'évacuation

**Ezy-clean™**

**Equipped with the Ezy-clean™ system:** removable bowl and basket.  
**Équipées du système Ezy-clean™ :** panier et cuve amovibles.

**50**



**50**  
Black  
Noir

**Santos juicer**  
Painted 50 or chromed base 50C  
Perfect filtration + wide feeding chute  
**Santos juicer**  
Socle peint 50 ou socle chromé 50C  
Filtration parfaite + large introduction



**COLD  
PRESSED  
JUICES!**

JUS PRESSÉS  
À FROID!

Heavy duty counter-top cold press juicer for fruits, veggies and leafy greens.

XL feeding tube.

Extracteur de jus puissant pour fruits, légumes et herbes.

Goulotte d'introduction XL.

**DIFFERENT  
TYPES  
OF JUICE  
EXTRACTION**

DIFFÉRENTES  
MÉTHODES  
D'EXTRACTION

There are different processes to extract juice from fruits and vegetables.

Find the juicer adapted to your needs.

Il existe différents procédés permettant d'extraire le jus de fruits et légumes.

Trouvez l'appareil adapté à vos besoins.

**Squeeze  
Pressage**

**70** Citrus juicer  
Presse-agrumes



This juicer squeezes oranges, grapefruits, lemons and pomegranates. It is suitable for intensive use thanks to its high output.

Permet de presser les oranges, pamplemousses, citrons et grenades. Il est adapté à un usage intensif grâce à son débit élevé.

**Centrifuge  
Centrifugation**

**68** Juice extractor  
Centrifugeuse



Using centrifugal force, it extracts juice from various types of fruits and vegetables such as apples, carrots, beetroots... It is adapted to intensive use.

Par l'intermédiaire de la force centrifuge, elle extrait le jus de fruits et légumes variés tels que les pommes, carottes, betteraves... Elle est adaptée à une utilisation intensive.

**Slow press  
Pression lente**

**65** Cold press juicer  
Extracteur de jus



It presses very slowly all kinds of fruits, vegetables, and herbs, to extract maximum juice and to preserve vitamins and nutrients.

Presse très lentement les fruits, légumes et herbes pour en extraire un maximum de jus, tout en préservant les vitamines et les nutriments.

# Juice equipment

## L'équipement jus

Our main accessories  
Nos accessoires principaux

### CITRUS JUICERS PRESSE-AGRUMES



11



**Squeezer for grapefruit**  
Ogive Pamplemousse  
Ref #11103 - #38102



**Squeezer for limes**  
Ogive citron vert  
Ref #11150 - #38150



**Squeezer for orange + lemon**  
Ogive orange + citron  
Ref #11101 - #38101



38



**Yellow bowl**  
Cuve jaune  
Ref #11204NJ - #38203NJ



**Black bowl**  
Cuve noire  
Ref #11204NN



**Plastic filter grid**  
Grille plastique  
Ref #11201 - #38201



**Ornamental ring**  
Cercle anodisé  
Ref #11202 - #38202



52C



**Squeezer for grapefruit**  
Ogive Pamplemousse  
Ref #52200



**Squeezer for limes**  
Ogive citron vert  
Ref #52150



**Squeezer for orange + lemon**  
Ogive orange + citron  
Ref #52100



**Stainless steel bowl**  
Cuve inox  
Ref #52301



**Anti splash dome**  
Dome anti projection  
Ref #52303



**Stainless steel pulp grid**  
Grille à pulpe inox  
Ref #52302



10



**Complete squeezer**  
Ogive complète  
Ref #10200



70



**Complete squeezer**  
Ogive complète  
Ref #70200

### JUICE EXTRACTORS CENTRIFUGEUSES



68



**Basket: holes 0,5mm**  
Panier : trous 0,5mm  
Ref #68200



**Basket: holes 0,8mm**  
Panier : trous 0,8mm  
Ref #68200B



**Autoclean basket**  
Panier autoclean  
Ref #68200C



**Kit Chefs & Pâtisserie**  
Kit Chefs et pâtisserie  
Ref #68110



**Pulp tube**  
Tube à pulpe  
Ref #68960



50



**Basket: holes 0,5mm**  
Panier : trous 0,5mm  
Ref #50200



**Basket: holes 0,8mm**  
Panier : trous 0,8mm  
Ref #50200B



**Autoclean basket**  
Panier autoclean  
Ref #50200C

### COLD PRESS JUICER EXTRACTEUR DE JUS



65



**Complete wiper**  
Racleur complet  
Ref #65260



**Complete 0,3 filter**  
Filtre complet 0,3  
Ref #65220

# Bar equipment Équipements de bar

Find the right equipment for your cocktails! Crush, mix, blend, emulsify your ingredients, for the perfect drink!

Trouvez l'équipement adapté à vos cocktails ! Broyez, mixez, mélangez, émulsionnez vos ingrédients pour des boissons parfaites !



**54**

### **Drink mixer**

Prepare milkshakes and all types of creamy and frozen cocktails

### **Shaker électrique**

Préparez des milkshakes et toutes sortes de cocktails crémeux et glacés

**62**

### **Brushless Blender**

Make your frozen cocktails, with ice cubes and frozen fruits

### **Blender Brushless**

Mixez vos cocktails glacés, avec des glaçons et fruits congelés

*Let's have  
a drink!*

**53**

### **Ice Crusher**

Crush ice cubes for your cocktails and granitas

### **Broyeur à glaçons**

Broyez des glaçons pour vos cocktails et granitas



# Everything for the bar

| TOUT POUR LE BAR



**54**



**54**  
Black  
Noir

**Drink mixer, electric shaker**  
Speed variation, 2 bowls - 3 tools

**Shaker électrique, drink mixer**  
Variation de vitesse, 2 bols - 3 agitateurs



**33E**  
Green  
Vert



**33GE**  
Grey  
Gris



**33CE**  
Chrome  
Chromé



**33GE**

**Bar blender 33 Evolution (1.25 litre container)**  
Painted base 33E - 33GE or chromed base 33CE

**Mixer de bar 33 Evolution (bol 1,25 litre)**  
Socle peint 33E - 33GE ou socle chromé 33CE

**62**



**62**  
Black  
Noir

**Brushless blender**

Extremely efficient, silent and easy to use, it is the perfect appliance to make smoothies and iced drinks. It crushes all kinds of ice cubes.

**Blender brushless**

Extrêmement performant, silencieux et simple à utiliser, il est l'outil parfait pour réaliser les smoothies et boissons glacées. Il broie tous types de glaçons.

## Brushless motor

MOTEUR  
BRUSHLESS

**Brushless motor: extended life expectancy, excellent energy efficiency and low noise level.**

**Moteur brushless : très grande durée de vie, excellent rendement énergétique et faible niveau sonore.**

**34-1**



**34-1**  
Stainless  
steel  
Inox

**Cold drink dispenser (1 bowl x 12 l)**  
Available with 2 bowls 34-2 or 3 bowls 34-3  
Accepts fruit pieces, High quality compressor

**Distributeur de boissons réfrigérées (1 bac x 12 l)**  
Disponible avec 2 bacs 34-2 ou 3 bacs 34-3  
Accepte les morceaux de fruits, compresseur haute qualité



# Bar essential

L'INCONTOURNABLE  
POUR VOTRE BAR

It is adapted to intensive use and allows a hands free use thanks to its high capacity tank 1.2kg.

Adapté à une utilisation intensive et permet un fonctionnement « main libres » grâce à son réservoir à glaçons de 1,2 kg.



## Bar equipment L'équipement bar

Our main accessories  
Nos accessoires principaux

### BLENDERS BLENDEURS



62



**Complete bowl**  
Bol complet  
Ref #62100



**Complete yellow bowl**  
Bol complet jaune  
Ref #62100Y



**Complete red bowl**  
Bol complet rouge  
Ref #62100R



**Complete blade**  
Ensemble couteaux  
Ref #62110



33



**Complete bowl**  
Bol complet  
Ref #33100



**Complete blade**  
Ensemble couteaux  
Ref #33107

### ICE CRUSHER BROYEURS À GLAÇONS



09



**Drawer**  
Tiroir  
Ref #09502



**Crushing disc**  
Disque de brise glace  
Ref #09201



53



**Ice bucket**  
Bac à glaçons  
Ref #53850

09



09  
Beige  
Beige

#### Traditional Ice shaver

Delivered with one adjustable disc for snow ice and crushed ice.

#### Broyeur à glaçons traditionnel

Livré avec un disque réglable pour neige et glace pilée.

53



53  
Grey  
Gris

#### Ice crusher

Two sizes of crushed ice. Perfect for cocktails (caipirinhas, mojitos...)

#### Broyeur à glaçons

2 tailles de glace pilée. Parfait pour les cocktails (caipirinhas, mojitos, ...)

### DRINK MIXER SHAKER ÉLECTRIQUE



54



**Transparent bowl**  
Bol transparent  
Ref #54105



**Stainless steel bowl**  
Bol inox  
Ref #54101



**Spherical agitator**  
Agitateur sphérique  
Ref #54201



**Winged agitator**  
Agitateur à ailettes  
Ref #54203



**Soft agitator**  
Agitateur souple  
Ref #54202

Inspiration  
and precision

## Snacking solution

### Solutions pour le snacking

Your partner in food preparation since 1954. We offer a complete range of products for all needs, from the preparation of your appetizer to the creation of desserts.

Santos est votre partenaire en préparation culinaire depuis 1954. Nous offrons une gamme complète de produits qui répond à vos besoins, de la préparation de l'entrée jusqu'à la création du dessert.



**37**

#### **Kitchen blender**

Make soups, gazpachos, purées, vegetable foams, creams...

#### **Blender de cuisine**

Réalisez des soupes, gazpachos, purées, mousses de légumes, crèmes, glaces...

**48**

#### **Vegetable slicer**

Cut, slice, grate and shred your vegetables and cheese

#### **Coupe-légumes**

Coupez, tranchez, râpez, émincez et effilez vos légumes et fromages

**12**

#### **Meat mincer**

Prepare ground beef, hamburger steaks, sausages, and pâtés

#### **Hachoir à viande**

Préparez vos viandes hachées, saucisses, terrines...

**27**

#### **Planetary mixer**

Mix, knead, beat, and whip all kinds of preparations

#### **Batteur mélangeur**

Mélangez, pétrissez, battez et fouettez toutes sortes de préparations

# Unleash your creativity

LAISSEZ LIBRE COURS  
À VOTRE CRÉATIVITÉ



## YOUR PARTNER IN THE KITCHEN

VOTRE PARTENAIRE  
EN CUISINE



37 41  
Grey  
Gris

**Santosafe kitchen blender** painted base 37

**Blender de cuisine Santosafe** socle peint 37

**37 41**

**02**



02  
Beige  
Beige

**Grater** (1 standard disc Ø 3mm)

**Râpe** (1 disque standard Ø 3 mm)

02

**18**



18  
Beige  
Beige

**10 litre dough mixer**

Stainless steel bowl

The ideal dough mixer to make 4kg of hard dough

**Pétrin mélangeur 10 litres**

Cuve inox

Le pétrin idéal pour réaliser 4 kg de pâte dure

18

## THE BEST VALUE FOR MONEY ON THE MARKET

LE MEILLEUR RAPPORT  
QUALITÉ/PRIX DU MARCHÉ !



48  
Grey  
Gris

**Vegetable slicer with high output**

Delivered with 3 standard discs: Slicer T3, Grater R3, Shredder E8. A wide range of discs available on demand

**Coupe légumes à gros débit**

Livré avec 3 disques standards : Trancheur T3, Râpe R3, Effileur E8. Une large gamme de disques disponibles sur demande

**48**

**27**



27  
Beige  
Beige

**10 litre planetary mixer**

3 planetary tools - 8 speeds

**Batteur mélangeur 10 litres**

3 accessoires planétaires - 8 vitesses

27

Mix, liquefy and crush all kinds of hot and cold preparations:

- Powerful motor and new pulse function (18000rpm)
- High quality blending
- Exclusive patented Santosafe® locking system for the bowl and the cover

Mixez, émulsionnez et broyez toutes sortes de préparations chaudes ou froides :

- Moteur puissant et fonction pulse (18000 tr/min)
- Qualité de mixage optimale
- Système de sécurité exclusif Santosafe® verrouillant le bol et le couvercle.



2 L



2 P



4 L



4 P

Choose your bowl  
Choisissez votre bol

**12-12R**



12-12  
Stainless  
Steel  
Inox



12-12R  
Red  
Rouge

**Meat mincer**

Stainless steel body.

Delivered with 3 plates Ø 70 mm

**Hachoir à viande corps inox**

Livré avec 3 grilles Ø 70 mm

# Food equipment

## L'équipement cuisine

Our main accessories  
Nos accessoires principaux

### GRATER RÂPE



02



**Grating disc 2mm**  
Disque 2mm  
Ref #02201AD



**Grating disc 3mm**  
Disque 3mm  
Ref #02201BD



**Grating disc 4mm**  
Disque 4mm  
Ref #02201CD



**Grating disc 6mm**  
Disque 6mm  
Ref #02201DD



**Grating disc 8mm**  
Disque 8mm  
Ref #02201ED



**Parmesan disc**  
Disque parmesan  
Ref #02201FD



**Fondue disc**  
Disque fondue  
Ref #02201GD



**Drawer**  
Tiroir  
Ref #01502

### MEAT MINCER HACHOIR À VIANDE



12-12R



**Plate 3mm**  
Grille 3mm  
Ref #12711



**Plate 4,5mm**  
Grille 4,5mm  
Ref #12712



**Plate 8mm**  
Grille 8mm  
Ref #12713B



**Set of 3 sausage cones**  
Jeu de 3 cornets  
à saucisses  
Ref #12804

+



**Plate 20 mm**  
Grille 20mm  
Ref #12803

### DOUGH MIXER PÉTRIN MÉLANGEUR



18



**Complete bowl**  
Cuve complète  
Ref #18500



**Dough-hook**  
Fourche  
Ref #18120

### VEGETABLE SLICER COUPE LÉGUME



48



**Grating disc**  
Disque râpe  
2mm: Ref #4820OR2  
3mm: Ref #4820OR3  
4mm: Ref #4820OR4



**Parmesan disc**  
Disque parmesan  
Ref #4820ORP



**Tomato slicing disc**  
Disque trancheur tomate  
4mm: Ref #4820OTD4  
6mm: Ref #4820OTD6



**Slicing disc**  
Disque trancheur  
1mm: Ref #4820OT1  
2mm: Ref #4820OT2  
3mm: Ref #4820OT3  
4mm: Ref #4820OT4  
5mm: Ref #4820OT5  
6mm: Ref #4820OT6



**Rosti Grating Disc**  
Disque rape rosti  
Ref #4820ORR



**Shredding disc**  
Disque effileur  
Ref #4820OE8



**Shredding disc**  
Disque effileur  
2mm: Ref #4820OE2  
4mm: Ref #4820OE4



**Ondulated slicing disc**  
Disque trancheur ondulé  
Ref #4820OTO4

### PLANETARY MIXER BATTEUR MÉLANGEUR



27



**Dough hook**  
Crochet complet  
Ref #27102



**Wire whip**  
Fouet complet  
Ref #27105



**Flat beater**  
Palette de batteur  
Ref #27101

### BLENDER BLENDER



37



**Complete 2L Stainless Steel bowl**  
Bol complet 2L inox  
Ref #21



**Complete 2L bowl**  
Bol complet 2L  
Ref #2P



**Complete 4L Stainless Steel bowl**  
Bol complet 4L inox  
Ref #4I



**Complete 4L bowl**  
Bol complet 4L  
Ref #4P



**Complete blade**  
Ensemble couteaux  
Ref #37180

# Coffee shop equipment

## Équipements pour coffee shops

Santos has been manufacturing high-quality coffee grinders and grinding discs since 1954, for a perfect coffee.

- Quietest grinders on the market
- Constant dose dispensed
- Heat dissipation
- Anti-static system
- Easy adjustment and maintenance

Santos fabrique des moulins à café et meules de broyage depuis 1954, et offre des équipements de qualité pour un café parfait.

- Moulins les plus silencieux du marché
- Régularité de dose
- Dissipation thermique
- Système antistatique
- Réglages et maintenance faciles



Quality  
and passion

### 63

**Coffee shop grinder**  
Ideal to quickly grind large quantities of coffee beans

**Moulin à café coffee shop**  
Parfait pour moulin de grandes quantités de grains de café, en un temps record

### 55WBC

**Espresso Coffee Grinder**  
Grind your coffee on-demand for a high quality espresso

**Moulin à café Espresso**  
Moulez votre café à la demande pour un espresso de qualité

### 01BAR

**Barista Coffee Grinder**  
Prepare your specialty coffee with this high precision grinder

**Moulin à café Barista**  
Préparez vos cafés de spécialité avec une précision extrême

### 04N

**Shop Coffee grinder**  
Offer freshly ground coffee in bags, for all types of filtrations

**Moulin à café boutique**  
Offrez des sacs de café fraîchement moulu, pour tous types de filtrations

# Espresso coffee

CAFÉ  
EXPRESSO



**26**



26  
Black  
Noir

**Tabletop precision coffee dispenser**  
Doseur expresso de précision sur socle

**Automatic**  
Automatique

**55 BF**



25 kg/h



63 dB



55 BF  
Black  
Noir



**Automatic silent espresso coffee grinder**  
Black Front Panel 55 BF

**Moulin à café expresso silencieux "automatique"**  
Façade noire 55 BF

**06 A**



8 kg/h



06 A  
Brown  
Brun



**Espresso coffee grinder**  
Moulin à café bar

**40 AN**



8 kg/h



63 dB



40 AN  
Black  
Noir



40 A  
Brown  
Brun



**Silent espresso coffee grinder**  
Available with mobile coffee tamper 40APPM

**Moulin à café bar silencieux**  
Disponible avec presse-poudre mobile 40APPM

## CHOOSE YOUR VERSION

CHOISISSEZ VOTRE VERSION

The "Automatic" silent espresso coffee grinder #55 dispenses the precise dose of coffee for 1 or 2 espressos directly into the filter holder, which gives you the guarantee of a fresh ground coffee.

Le moulin à café expresso silencieux « automatique » n°55 distribue directement dans le porte-filtre la dose de café nécessaire pour 1 ou 2 espressos, ce qui garantit un café moulu ultra frais.

**55 W**



White  
Blanc

**55 WBC**



White  
Blanc

**55 BM**



Shiny grey  
Gris émerisé

**55 BMS**



Shiny grey  
Gris émerisé

**55 BAR**



Black  
Noir

**75**



75  
Black  
Noir



**Espresso coffee machine (1 group)**  
"Santos Espresso"

**Machine à café expresso (1 groupe)**  
"Santos Espresso"

# Coffee shop grinders

MOULINS À CAFÉ  
BOUTIQUES  
ET COFFEE SHOPS



**04 N**



**04N**  
Black  
Noir



**04**  
Brown  
Brun

**Coffee grinder with bag holder**  
**Moulin à café Pince-sac**



**01**



**01**  
Brown  
Brun

**Coffee grinder with drawer**  
Available with bag holder 01 PS, in pepper grinder version with drawer 01 P or in poppy grinder version 01 PV

**Moulin à café tiroir**  
Disponible avec pince-sac 01 PS, en moulin à poivre - tiroir 01 P ou en moulin à pavot 01 PV



**42**



**42**  
Stainless  
Steel  
Inox

**Silent portion coffee grinder with timer**  
Brew baskets or drawer adaptable, delivered with drawer

**Moulin à café silencieux avec minuterie**  
Porte-filtres ou tiroir adaptables, livré avec tiroir



**01 BAR**



**01BAR**  
Black  
Noir

**Coffee Grinder - Championship Edition**  
1954 Barista series

**Moulin à café Edition barista**  
1954 Barista series



**43 N**



**43N**  
Black  
Noir

**Silent shop coffee grinder with bag holder**  
Painted Black 43N

**Moulin à café boutique silencieux Pince-sac**  
Noir 43N

**63**



120 kg/h



**63**  
Black  
Noir



**Coffee shop grinder:**

- Exceptional output: up to 120 kg/h
- Micrometric setting of the grinding fineness
- Makes turkish coffee (output: 36 kg/h)
- Extremely silent
- Santos Ø 120mm grinding discs

**Moulin coffee shop :**

- Débit exceptionnel : jusqu'à 120 kg/h
- Réglage de mouture micrométrique
- Permet de réaliser du café turc (débit : 36 kg/h)
- Extrêmement silencieux
- Meules Santos Ø 120 mm



**Santos Ø 120 mm grinding discs**  
Santos offers the possibility to resharpen your grinding discs to give them a second life.

**Meules Santos Ø 120 mm**  
Santos offre la possibilité de faire réaffûter vos meules pour leur donner une seconde vie.





# Coffee section

## La section café

### Our main accessories

Nos accessoires principaux

01 BAR, 04 N, 06 A



**01 BAR**

**04 N**

**06 A**

**Complete hopper**  
Bac à grains complet  
Ref #01100

**Complete black hopper**  
Bac à grains complet noir  
Ref #01100N

01/01P

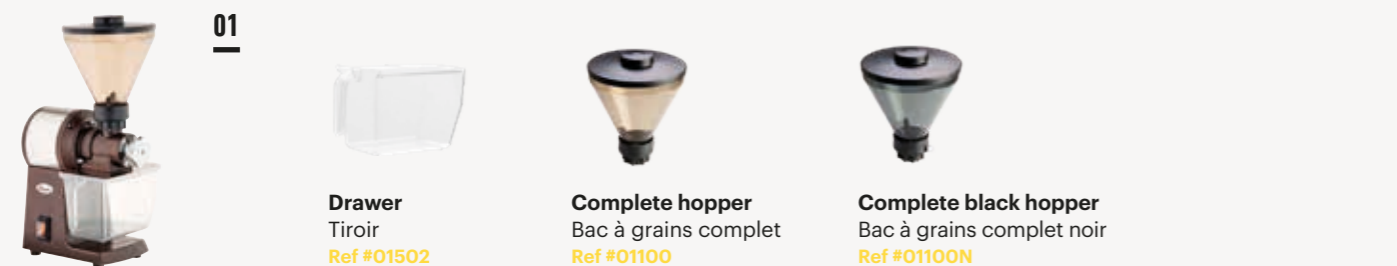

**01**

**Drawer**  
Tiroir  
Ref #01502

**Complete hopper**  
Bac à grains complet  
Ref #01100

**Complete black hopper**  
Bac à grains complet noir  
Ref #01100N

40 AN/55

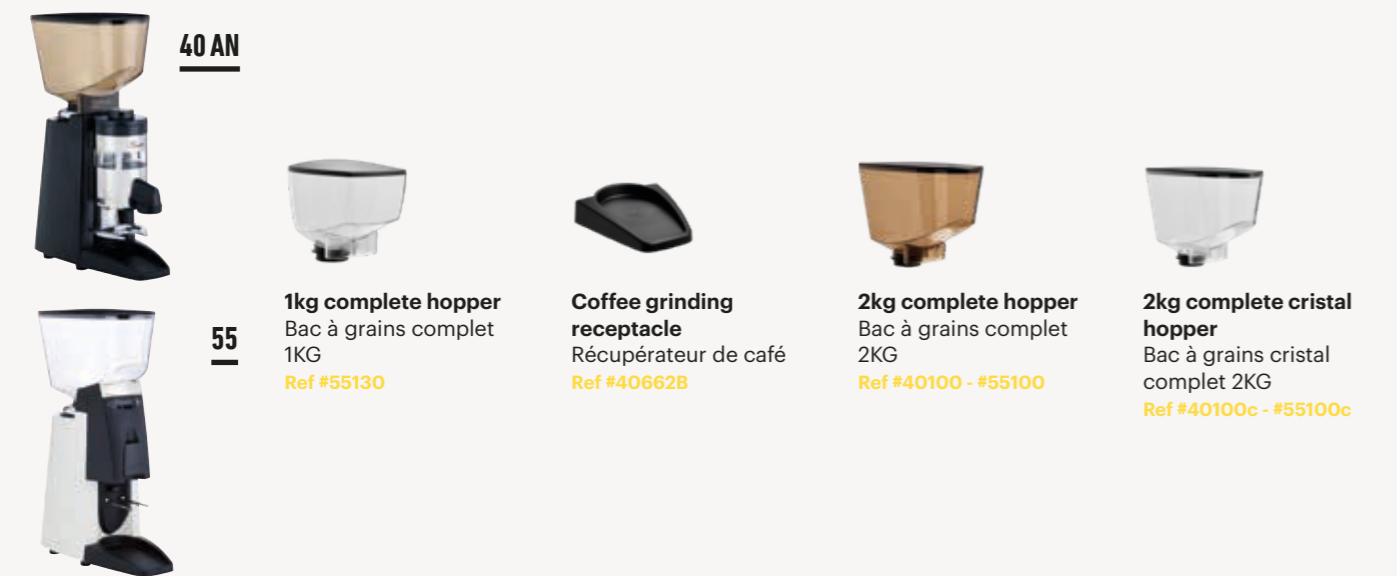

**40 AN**

**55**

**1kg complete hopper**  
Bac à grains complet  
1KG  
Ref #55130

**Coffee grinding receptacle**  
Récupérateur de café  
Ref #40662B

**2kg complete hopper**  
Bac à grains complet  
2KG  
Ref #40100 - #55100

**2kg complete cristal hopper**  
Bac à grains cristal  
complet 2KG  
Ref #40100c - #55100c

01, 04, 06, 40, 42, 43 and 55 GRINDING DISCS MEULES

For every grinder  
except #63

Pour tous les  
moulins sauf n° 63



**Poppy seeds discs**  
Meules pavot  
Ref #00011



**Pepper grinding discs**  
Meules poivre  
Ref #00002N



**Coffee grinding discs**  
Meules  
Ref #00001B

63



**Grinding discs ø 120mm**  
Meules 120mm  
Ref #00063

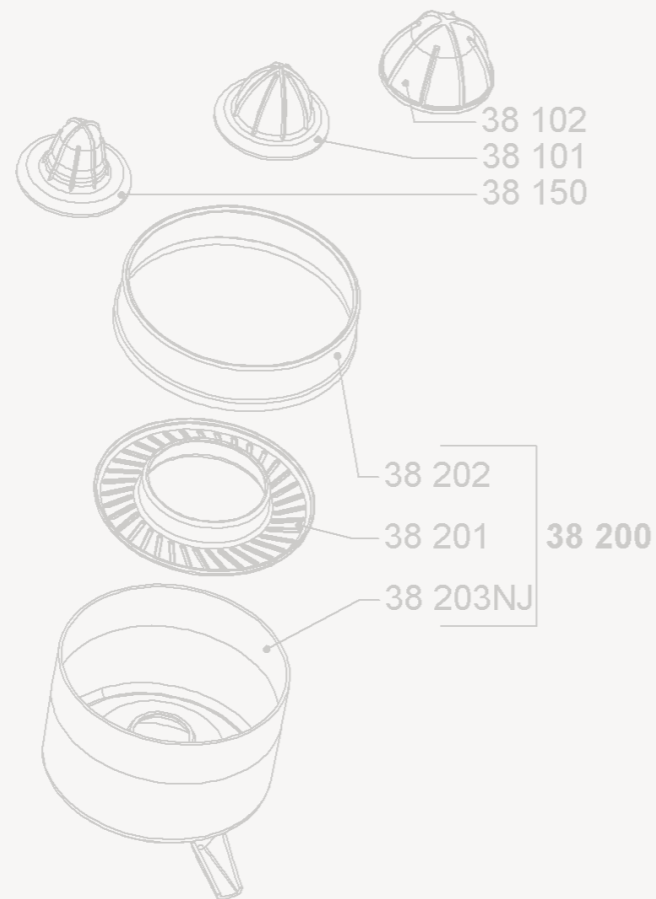

## DONNÉES TECHNIQUES Technical data

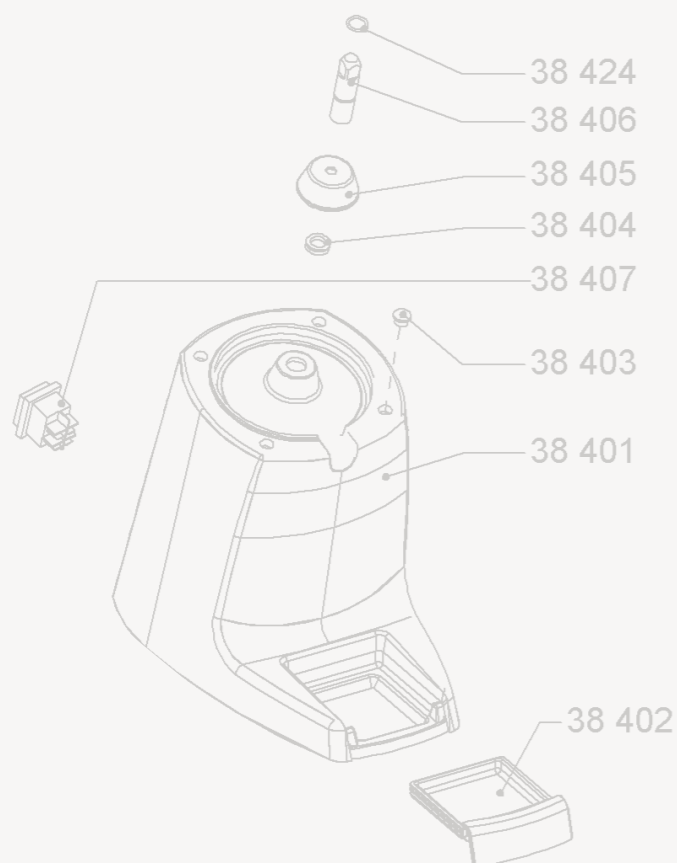

## Juice range Gamme Jus

Reference Référence	Available voltages Voltages disponibles	Power Puissance (W)	Speed at 50Hz Vitesse à 50Hz (rpm; tr/min)	Specifications Spécifications	Standards Normes		Colors Couleurs				Dimensions (DxWxH) mm (P x L x H) mm	Net weight (kg) Poids net (kg)		
					CE	GS	UL / ETL	NSF	KC	EAC			Longtime	Stainless Steel   inox
<b>Citrus juicers   Presse agrumes</b>														
71C	Mefra citrus juicer - chromed base (1 squeezer) Presse agrumes Mefra socle chromé (1 ogive)	71C	220-240V-50/60Hz	40	80	15 l/h	●						236x170x310	3,5
	71CV1	100-120V-50/60Hz	40											
11	"Classic" citrus juicer (3 squeezers) Presse agrumes « Classic » (3 ogives)	11 / 11G / 11C	220-240-50/60Hz	130	1500	30 l/h	●		●	●	●	●	300x230x350	5
		11V1 / 11GV1 / 11CV1	100-120V-50/60Hz	155										
38	Citrus juicer (3 squeezers) Presse agrumes (3 ogives)	38 / 38G / 38C	220-240-50/60Hz	130	1500	30 l/h	●	●	●	●	●	●	303x170x350	5
		38V1 / 38GV1 / 38CV1	100-120V-50/60Hz	155										
52	Citrus juicer - painted base (3 squeezers) Presse agrumes - socle peint (3 ogives)	52G / 52C	220-240-50/60Hz	230	1500	40 l/h	●	●	●	●	●	●	305x205x490	9,5
		52GV1 / 52CV1	100-120V-50/60Hz	260										
10	Automatic citrus juicer with lever Presse agrumes à levier	10 / 10C	220-240V-50/60Hz	230	1500	30 l/h	●	●	●	●	●	●	300x200x380	9,5
		10V1 / 10CV1	100-120V-50/60Hz	260										
70	Lever Juicer Evolution 70 (1 squeezer) Presse agrumes à levier 70 Evolution (1 ogive)	70 / 70C	220-240V-50/60Hz	300	1500	50 l/h	●	●	●	●	●	●	400x240x490	13,5
		70V1 / 70CV1	100-120V-50/60Hz	350										
32 Bac	Automatic orange juicer with drip tray Presse oranges automatique avec repose verre	32Bac	220-240V-50Hz	600	1500	100 l/h	●		●	●			620x410x1020	65,5
		32BacV4	220-240V-60Hz	600										
		32BacV1	100-120V-50/60Hz	650										
32T	Automatic orange juicer, with stainless steel table Presse-oranges automatique avec table inox	32T	220-240V-50Hz	600	1500	100 l/h	●		●	●			770x410x1810	86,5
		32TV4	220-240V-60Hz	600										
		32TV1	100-120V-50/60Hz	650										
<b>Juice extractors   Centrifugeuses</b>														
68	New generation centrifugal juice extractor "Miracle edition" Centrifugeuse nouvelle génération « Miracle Edition »	68	220-240V-50/60Hz	1300	3000	140 l/h	●	●	●	●	●	●	562x330x606	25
		68V1	100-120V-50/60Hz	1300										
50	"Santos Juicer" (Ezy-Clean™ System) « Santos Juicer » (Système Ezy-Clean™)	50 / 50C	220-240V-50/60Hz	800	3000	100 l/h	●	●	●	●	●	●	470x260x450	14
		50V1 / 50CV1	100-120V-50/60Hz	800										
28	Centrifugal juice extractor Centrifugeuse	28	220-240V-50/60Hz	1300	3000	100 l/h	●	●	●	●	●	●	480x320x570	24
		28V1	100-120V-50/60Hz	1300										
<b>Cold Press Juicer   Extracteur de jus</b>														
65	Cold press juicer Extracteur de jus	65	220-240V-50/60 Hz	650	5-80	60l/h	●	●					412x233x640	31
		65V1	100-120V-50/60 Hz											

Standards | Normes :  
 ● Approved | Approuvé  
 ▲ Pending | En cours

## Bar range Gamme Bar

Blenders, Drink mixers   Mixeurs, Shakers électriques																	
Reference Référence	Available voltages Voltages disponibles	Power Puissance (W)	Speed at 50Hz Vitesse à 50Hz (rpm; tr/min)	Specifications Spécifications	Standards Normes								Colors Couleurs			Dimensions (DxWxH) mm (P x L x H) mm	Net weight (kg) Poids net (kg)
					CE	GS	UL/ETL	NSF	KC	EAC	Longtime	Stainless Steel   Inox	Chrome   Chromé	Black   Noir	Grey   Gris		
62	Brushless blender Blender Brushless	62	220-240V-50/60Hz	1500	15000	2,4 l	●		●	●	●				247x200x 440	9,5	
		62V1	100-120V-50/60Hz	1500				●	●	●	●						
54	Drink mixer, electric shaker Shaker électrique, drink mixer	54 / 54R / 54G	220-240V-50/60Hz	230	8000 - 16000	0,675 l	●	●	●	●	●				186x182x530	6	
		54V1 / 54RV1 / 54GV1	100-120V-50/60Hz	230													
33E	Bar blender Evolution – bowl detection Mixeur de bar Evolution – détection de bol	33E / 33GE / 33CE	220-240V-50/60Hz	600	13000 - 16000	1,25 l	●				●	●	●		180x180x 420	3	
		33EV1/33GEV1/33CEV1	100-120V-50/60Hz	600													
Ice crushers   Broyeurs à glaçons																	
9	Ice shaver Broyeur à glaçons	09	220-240V-50Hz	600	1500	1,6 kg/min	●			●					420x250x 350	14,5	
		09V4	220-240V-60Hz	600													
		09V1	100-120V-50/60Hz	650				●									
53	Ice crusher Broyeur à glaçons	53	220-240V-50/60Hz	130	73	24 kg/min	●			●				353x236x 474	10		
		53V1	100-120V-50/60Hz					●									
Cold drink dispensers   Distributeurs de boissons																	
34-1	Cold drink dispenser (1 bowl x 12l) Distributeur de boissons réfrigérées (1 bac x 12 l)	34-1	220-240V-50Hz	160	-	12 l	●				●				430x190x 545	15,5	
		34-1V4	220-240V-60Hz														
		34-1V1	100-120V-50/60Hz														
34-2	Cold drink dispenser (2 bowls x 12l) Distributeur de boissons réfrigérées (2 bacs x 12 l)	34-2	220-240V-50Hz	260	-	2 x 12 l	●				●				430x380x 545	23,5	
		34-2V4	220-240V-60Hz														
		34-2V1	100-120V-50/60Hz														
34-3	Cold drink dispenser (3 bowls x 12l) Distributeur de boissons réfrigérées (3 bacs x 12 l)	34-3	220-240V-50Hz	330	-	3 x 12 l	●				●				430x570x 545	30,5	
		34-3V4	220-240V-60Hz														
		34-3V1	100-120V-50/60Hz														

Standards | Normes :  
● Approved | Approuvé  
▲ Pending | En cours

## Food range Gamme Cuisine

Kitchen blender   Blender de cuisine																	
Reference Référence	Available voltages Voltages disponibles	Power Puissance (W)	Speed at 50Hz Vitesse à 50Hz (rpm; tr/min)	Specifications Spécifications	Standards Normes								Colors Couleurs			Dimensions (DxWxH) mm (P x L x H) mm	Net weight (kg) Poids net (kg)
					CE	GS	UL	NSF	EAC	Longtime	Stainless Steel   Inox	Grey   Gris	Beige   Beige	Red   Rouge			
37	Santosafe® kitchen blender painted base only (without any bowl) Blender de cuisine Santosafe® socle peint (Base seule sans bol)	37	220-240V 50/60Hz	1200	0-1800	-	●				●	●	●		303 x 220 x 566	9	
374P	Santosafe® kitchen blender painted base – 4 litre (1 gallon) transparent container Blender de cuisine Santosafe® socle peint – Bol 4 litres Polymère (sans biphénol A)	374P	220-240V 50/60Hz	1200	0-1800	4L	●				●	●	●		303 x 220 x 566	11	
374I	Santosafe® kitchen blender painted base – 4 litre (1 gallon) stainless steel container Blender de cuisine Santosafe® socle peint – Bol 4 litres Inox	374I	220-240V 50/60Hz	1200	0-1800	4L	●				●	●	●		303 x 220 x 566	11	
372P	Santosafe® kitchen blender painted base – 2 litre (1/2 gallon) transparent container Blender de cuisine Santosafe® socle peint – Bol 2 litres Polymère (sans biphénol A)	372P	220-240V 50/60Hz	1200	0-1800	2L	●				●	●	●		303 x 220 x 566	11	
372I	Santosafe® kitchen blender painted base – 2 litre (1/2 gallon) stainless steel container Blender de cuisine Santosafe® socle peint – Bol 2 litres Inox	372I	220-240V 50/60Hz	1200	0-1800	2L	●				●	●	●		303 x 220 x 566	11	
10 litre dough mixer and planetary mixer   Pétrin et batteur mélangeur 10 litres																	
18	10 litre dough mixer (kneader) stainless steel bowl Pétrin mélangeur 10 litres – cuve inox	18	220-240V-50Hz	600	1500	4 kg	●							●	500 x 350 x 420	18	
		18V1	100-120V-50/60Hz	650													
27	10 litre mixer with 3 planetary tools 8 speeds Batteur mélangeur 10 litres avec 3 accessoires planétaires – 8 vitesses	27	220-240V-50Hz	600	1500	5 kg	●							●	530 x 360 x 580	31	
		27V3	Tri 380V-50Hz	510													
		27V1	100-120V-50/60Hz	650				●									
Grater   Râpe																	
02	Grater (1 standard disc) Râpe (1 disque standard)	02	220-240V-50Hz	600	1500	50 kg/h	●							●	420 x 250 x 350	14,5	
		02V4	220-240V-60Hz	600													
		02V1	100-120V-50/60Hz	650				●									
Vegetable Cutter   Coupe légumes																	
48	Vegetable slicer Coupe légumes	48	220-240V-50/60Hz	390	1000	300 kg/h	●						●	420 x 250 x 580	17		
Meat mincer   Hachoir à viande																	
12-12	Meat mincer – stainless steel mincer body Hachoir à viande – corps inox	12-12 / 12-12R	220-240V-50/60Hz	600	1500	160 kg/h	●							●	350 x 260 x 420	19	
		12-12V1 / 12-12RV1	100-120V-50/60Hz	650													

Standards | Normes :  
● Approved | Approuvé  
▲ Pending | En cours

## Coffee range

Gamme Café

	Reference Référence	Available voltages Voltage disponibles	Power Puissance (W)	Speed at 50Hz Vitesse à 50Hz (rpm; tr/min)	Specifications Spécifications	Standards Normes										Colors Couleurs			Dimensions (D x W x H) mm (P x L x H) mm	Net weight (kg) Poids net (kg)	
						CE	GS	UL	NSF	KC	EAC	Stainless Steel   Inox	Brown   Brun	Black   Noir	Shiny Grey   Gris émeraillé						
<b>Espresso coffee grinders   Moulins à café bar (espresso)</b>																					
06	Espresso coffee grinder Moulin à café bar	06	220-240V-50Hz	360	1500	8 kg/h	●										●	350x230x570	10		
		06V4	220-240V-60Hz	360																	
		06V1	100-120V-50/60Hz	310																	
06A	Automatic espresso coffee grinder Moulin à café bar doseur automatique	06A	220-240V-50Hz	360	1500	8 kg/h	●										●	350x230x570	10		
		06AV4	220-240V-60Hz	360																	
		06AV1	100-120V-50/60Hz	310																	
40A	Autom. silent espresso coffee grinder Moulin à café bar doseur auto. silencieux	40A / 40AN / 40AG	220-240V-50Hz	360	1500	8 kg/h	●										●	●	390x190x580	14	
		40AV4 / 40ANV4 / 40AGV4	220-240V-60Hz	360																	
		40AV1 / 40ANV1 / 40AGV1	100-120V-50/60Hz	310																	
55	Automatic espresso coffee grinder Moulin à café espresso automatique	55 / 55BF	220-240V-50/60Hz	1100	2800	25 kg/h	●										●	397x198x577	15		
		55V1 / 55BFV1	100-120V-50/60Hz	800																	
55BM 55BAR	Automatic espresso coffee grinder Blue Mountain and Black Moulin à café espresso automatique Blue Mountain et Black	55BM/55BAR	220-240V-50/60Hz	1100	2800	25 kg/h	●										●	●	397x198x577	15	
		55BMV1 / 55BARV1	100-120V-50/60Hz	800																	
<b>Precision coffee dispenser   Doseur Espresso de précision</b>																					
26	Tabletop precision coffee dispenser Doseur espresso de précision sur socle	-	-	-	-	-	●										●	293x200x352	4,3		
<b>Espresso coffee machine   Machine à café espresso</b>																					
75	Espresso coffee machine (1 group) "Santos espresso" Machine à café espresso (1 groupe) « Santos espresso »	75	220-240V-50/60Hz	1240	-	16 bar	●										●	320x265x400	17,5		
		75V1	100-120V-50/60Hz	1240																	
<b>Coffee shop grinders   Moulins à café boutiques et coffee shops</b>																					
01	Coffee grinder with drawer or bag holder Moulin à café — tiroir ou pince-sac	01	220-240V-50Hz	600	1500	14 kg/h	●											●	320x250x550	14	
		01V4	220-240V-60Hz	600																	
		01V1	100-120V-50/60Hz	650																	
01P	Pepper (spices) grinder with drawer Moulin à poivre (épices) — tiroir	01P	220-240V-50Hz	600	1500	14 kg/h	●											●	320x250x550	14	
		01PV4	220-240V-60Hz	600																	
		01PV1	100-120V-50/60Hz	650																	
01 BAR	Coffee grinder championship edition Moulin à café édition barista	01 BAR	220-240V-50/60Hz 100-120V-50/60Hz	600	1500-1800	14 kg/h	●										●	330x190x560	14,5		
04	Coffee grinder with bag holder Moulin à café — pince-sac	04	220-240V-50Hz	600	1500	14 kg/h	●											●	●	320x220x700	18
		04V4	220-240V-60Hz	600																	
		04V1	100-120V-50/60Hz	650																	
42	Silent portion coffee grinder Moulin à café doseur filtre silencieux	42	220-240V-50Hz	600	1500	14 kg/h	●											●	335x190x555	19	
		42V4	220-240V-60Hz	600																	
		42V1	100-120V-50/60Hz	650																	
43	Silent shop coffee grinder with bag holder Moulin à café boutique silencieux — pince-sac	43	220-240V-50Hz	600	1500	14 kg/h	●											●	335x190x690	20	
		43V4	220-240V-60Hz	600																	
		43V1	100-120V-50/60Hz	650																	
63	Coffee Shop Grinder Moulin à café Coffee Shop	63	220-240V-50Hz	1500	1500	120 kg/h	●											●	329x279x677	40	
		63V4	220-240V-60Hz																		
		63V1	100-120V-50/60Hz																		

Standards | Normes :  
 ● Approved | Approuvé  
 ▲ Pending | En cours



140-150, avenue Roger  
Salengro — BP 80 067  
69511 Vaulx-en-Velin  
Cedex (Lyon) France

Tél. : +33 4 72 37 35 29  
Fax : +33 4 78 26 58 21  
E-mail : [santos@santos.fr](mailto:santos@santos.fr)  
[www.santos.fr](http://www.santos.fr)

Follow us on **#santosaddict**  
social networks

